



EMERSON EXCHANGE 2025

ACCELERATING INNOVATION



ACCELERATING
INNOVATION

Beyond Conversion: Unlocking High-Performance Displays with DeltaV Live

May 2025

Disclaimer

The information and/or opinions expressed in this presentation are those of the authors and do not necessarily represent official policy or permission of Emerson or Emerson Exchange.

Important Reminders

Photography and audio/video recording is not permitted in any session, or in the exhibition areas, without press credentials or written permission from Emerson or Emerson Exchange.

Inquiries should be directed to:
EmersonExchange@Emerson.com



JUAN BUSTAMANTE

Automation Services Technical Manager / R.E. Mason

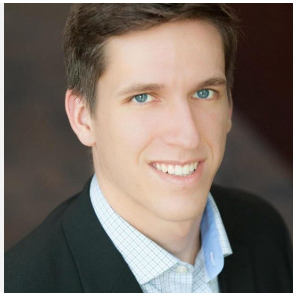

CARRSON OAKLEY

Project Execution Manager / R.E. Mason



Agenda

Customer Information

Redesign with Human Centered Design

Display Navigation

Watch Areas and Mini Faceplates

High-Performance GEMs

High-Performance Graphics

Conclusion

Company Info

CLARIANT

Globally Leading Company in Specialty Chemicals

5,198

Total Sales 2021 (CHF m)

**NORTH
AMERICA**

931, 18%

EUROPE

1,758, 34%

ASIA PACIFIC

1,514, 29%

AFRICA

364, 7%

**LATIN
AMERICA**

631, 12%

CLARIANT^E

Business Units



CARE CHEMICALS

- Personal & Home Care
- Crop Solutions
- Industrial Applications
- Base Chemicals
- Oil Services
- Mining Solutions

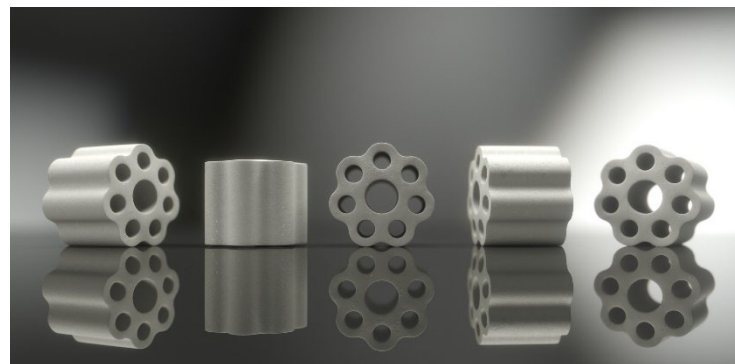

CATALYSTS

- Propylene
- Specialties
- Syngas & Fuels
- Ethylene
- Biofuels & Derivatives
- Applied Catalyst Technology

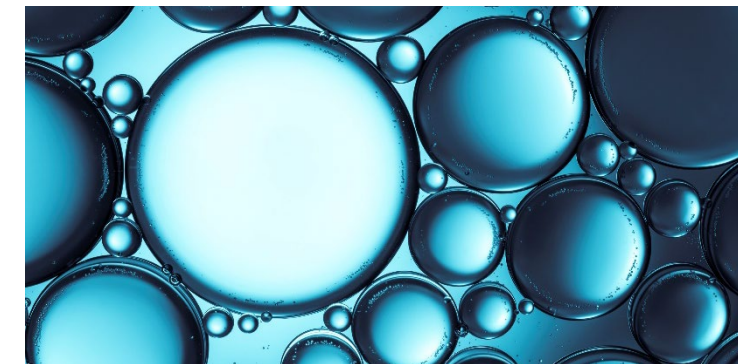

ABSORBENTS & ADDITIVES

- Adsorbents Purification¹
- Adsorbents Foundry & Specialties¹
- Adsorbents Cargo & Device Protection
- Additives Coatings & Adhesives
- Additives Plastics
- Additives E-Mobility & Electronics

CLARIANT 

Mount Holly, NC

- Business Unit: Care Chemicals
- 20 minutes from Downtown Charlotte
- Only Clariant Plant In North America on DeltaV
- Flagship Products: **DEET** and **Safewing**



Personal Care



Construction



Crop Solutions



Home Care

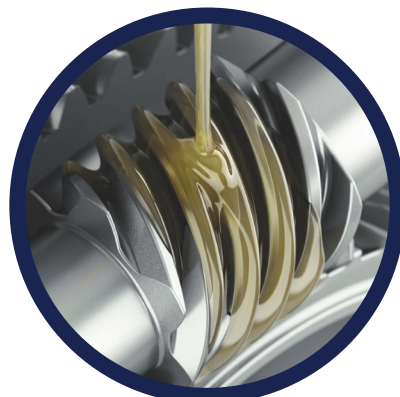

Industrial
Lubricants



Aviation



Paint & Coatings



Automotive

CLARIANT

Mount Holly, NC

- Four Separate DeltaV Systems Onsite:
 - Plant 3, Plant 4, Plant 5, and WWTP
 - Each Ran Independently with
 - DeltaV Operate Graphics for 20+ Years
- Decision made to begin merging DeltaV Systems in 2021
- Project initiated to standardize and modernize the existing operator graphics across the entire facility as systems were upgraded to DeltaV version 14+



Human Centered Design

Challenges Faced

odule: Main: RE02

RE02

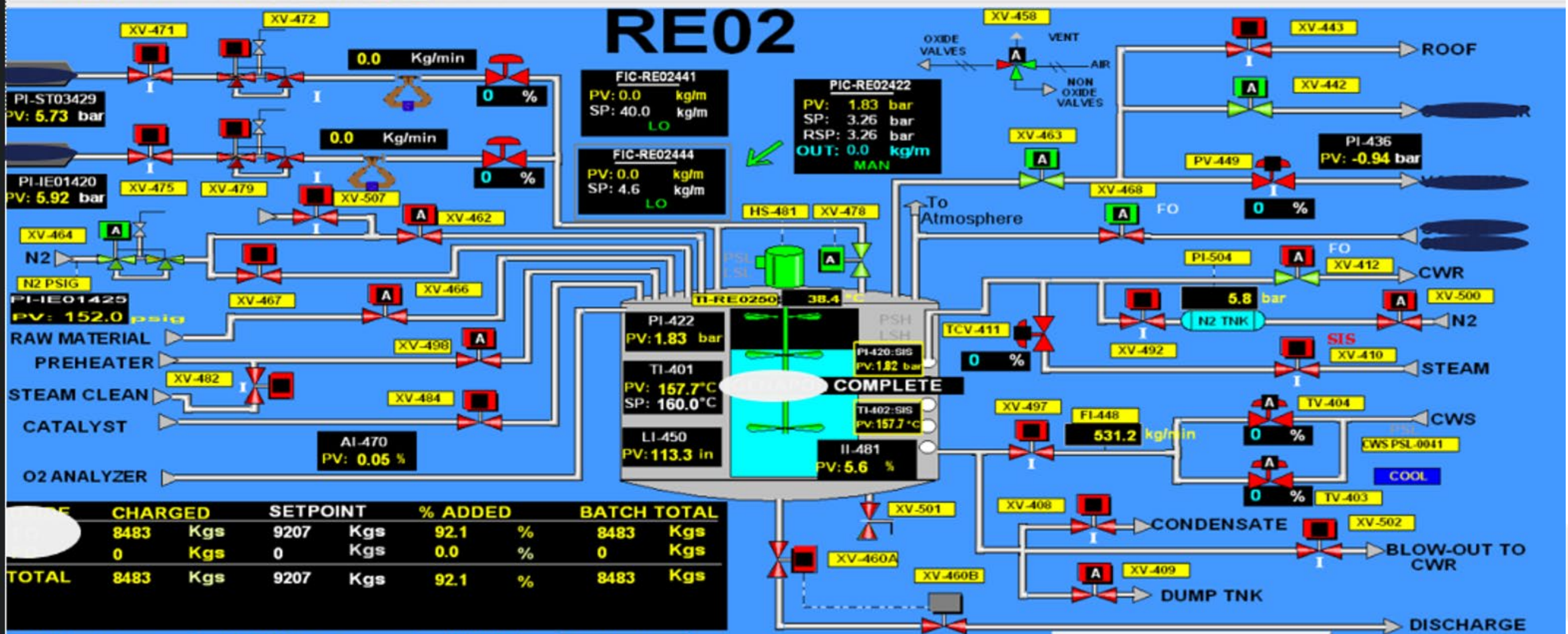

	CHARGED	SETPOINT	% ADDED	BATCH TOTAL
RAW MATERIAL	8483 Kgs	9207 Kgs	92.1 %	8483 Kgs
PREHEATER	0 Kgs	0 Kgs	0.0 %	0 Kgs
TOTAL	8483 Kgs	9207 Kgs	92.1 %	8483 Kgs

PN2 1.65 Bar PMAX 4.00 Bar PINERT 3.43 Bar

VENTING TO 0.5 BAR

Description	Recipe	Unit	Phase	Area

PROMPT ALARM SILENCE

ABORT

SIS RESET

C&E GRAPHICS

State of the System

- Significant variations in detail displays of similar module types.

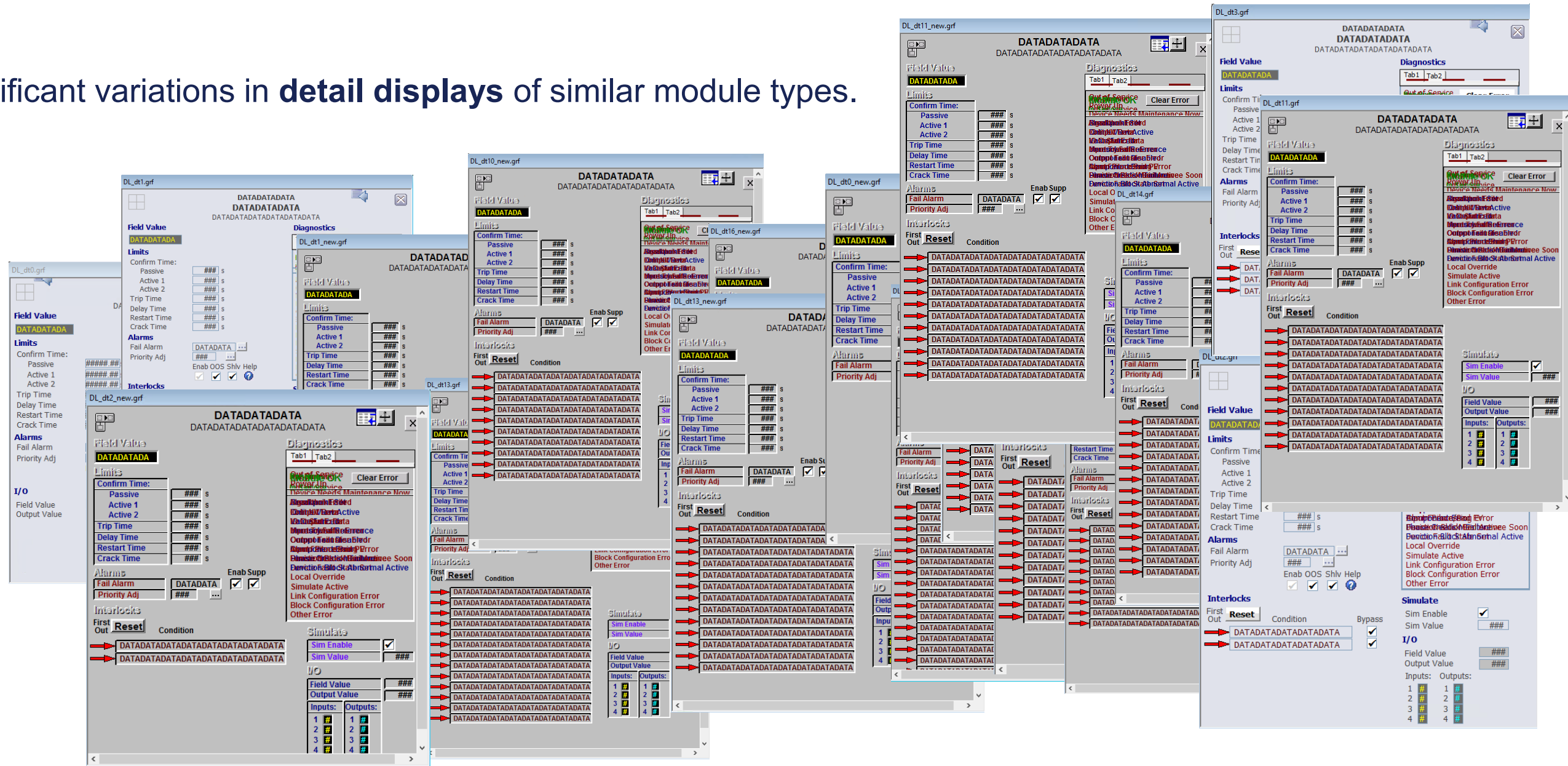

The image displays a collection of overlapping screenshots from an industrial control system. Each screenshot represents a different module's state, with labels like DL_dt1.grf, DL_dt10.new.grf, DL_dt0.new.grf, DL_dt11.new.grf, DL_dt3.grf, DL_dt2.new.grf, DL_dt13.grf, DL_dt16.new.grf, DL_dt14.grf, DL_dt15.grf, and DL_dt17.grf. The interfaces are highly detailed, featuring sections for:

- Field Value:** Shows various parameters such as Confirm Time, Active 1, Active 2, Trip Time, Delay Time, Restart Time, and Crack Time, often with numerical values and units.
- Limits:** Displays status for Passive, Active 1, and Active 2, along with associated time values.
- Alarms:** Includes sections for Fail Alarm, Priority Adj, and Enab Supp.
- Interlocks:** Shows 'First Out' and 'Reset' conditions with associated data.
- Diagnostics:** Lists various error codes and messages, such as 'Out of Service', 'Maintenance Mode', and 'Link Configuration Error'.
- Simulate:** Features 'Sim Enable' and 'Sim Value' controls.
- I/O:** Includes 'Field Value' and 'Output Value' sections with input/output tables.

The overlapping nature of the screenshots highlights the complexity and the subtle differences in the layout and data presentation of these similar module types.

State of the System

- Significant variations in **Dynamos** of similar module types.

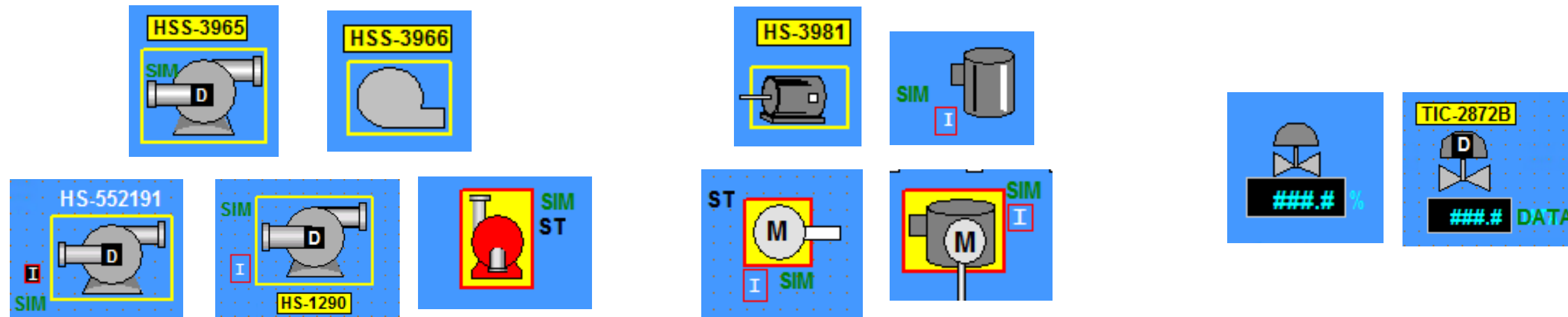

State of the System

- Significant variations in **line colors and thickness**

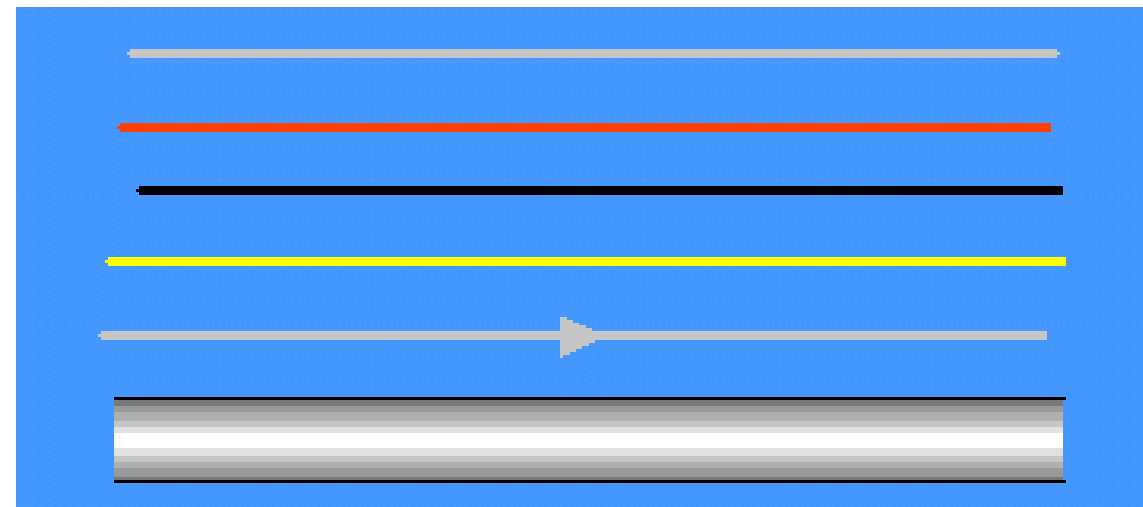
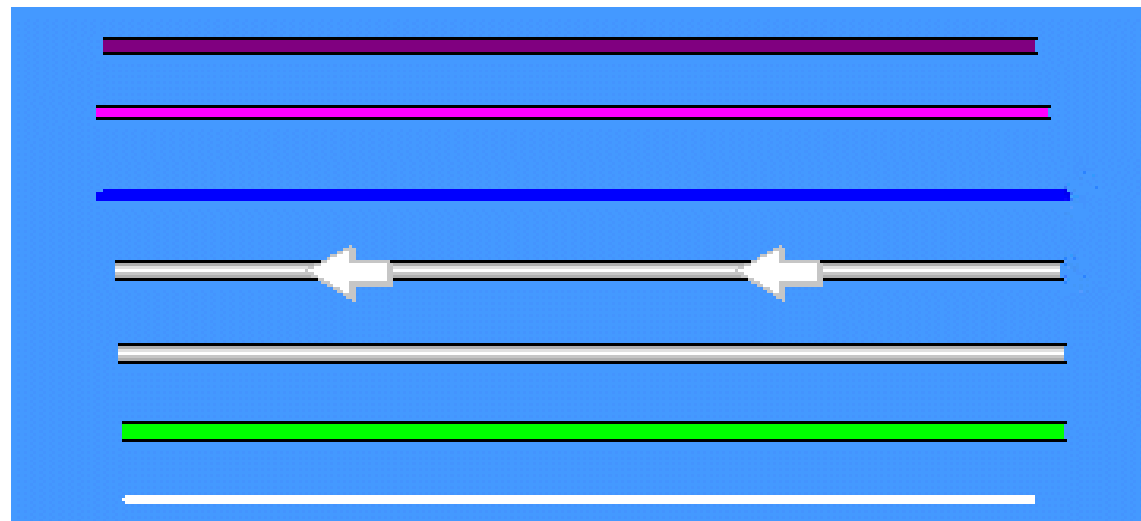

State of the System

- Deviation from Human Centered Design philosophy: Reds, Yellows, High Contrast used for Tag Names and Process Data

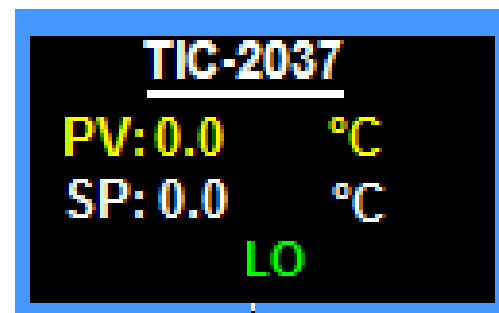
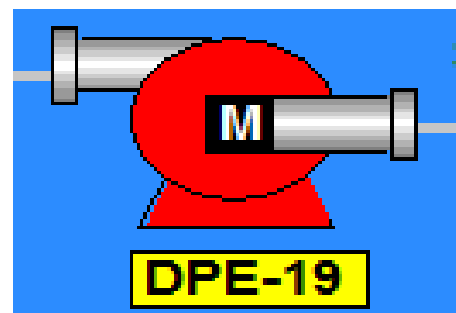
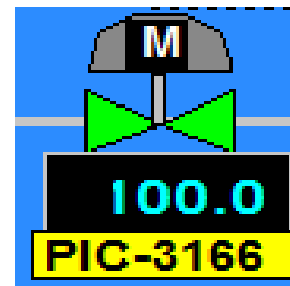
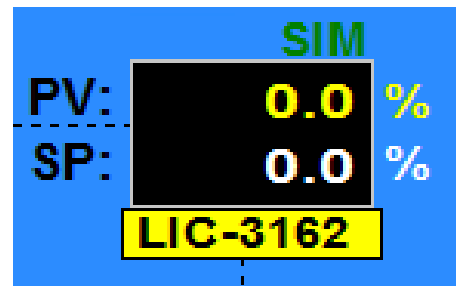



Redesign with Human Centered Design (HCD)

Human Centered Design

- Consistent faceplate displays created by referencing function block parameters only.

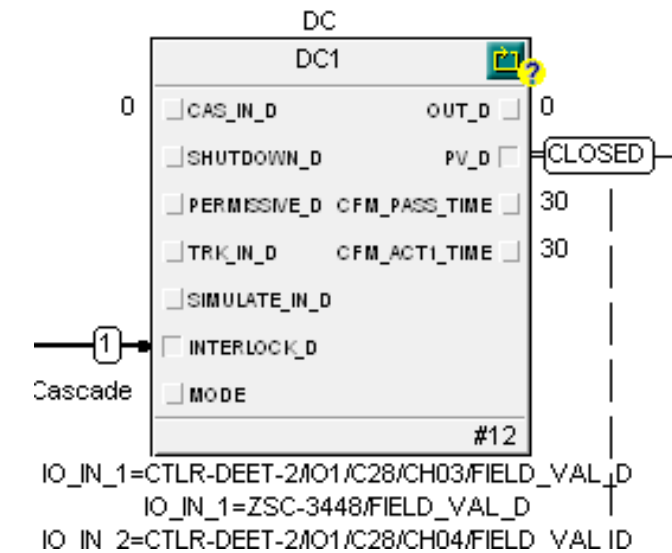
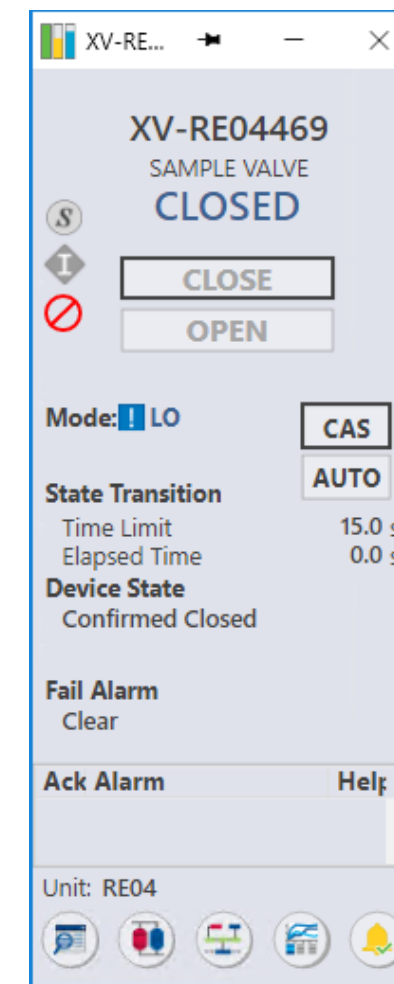
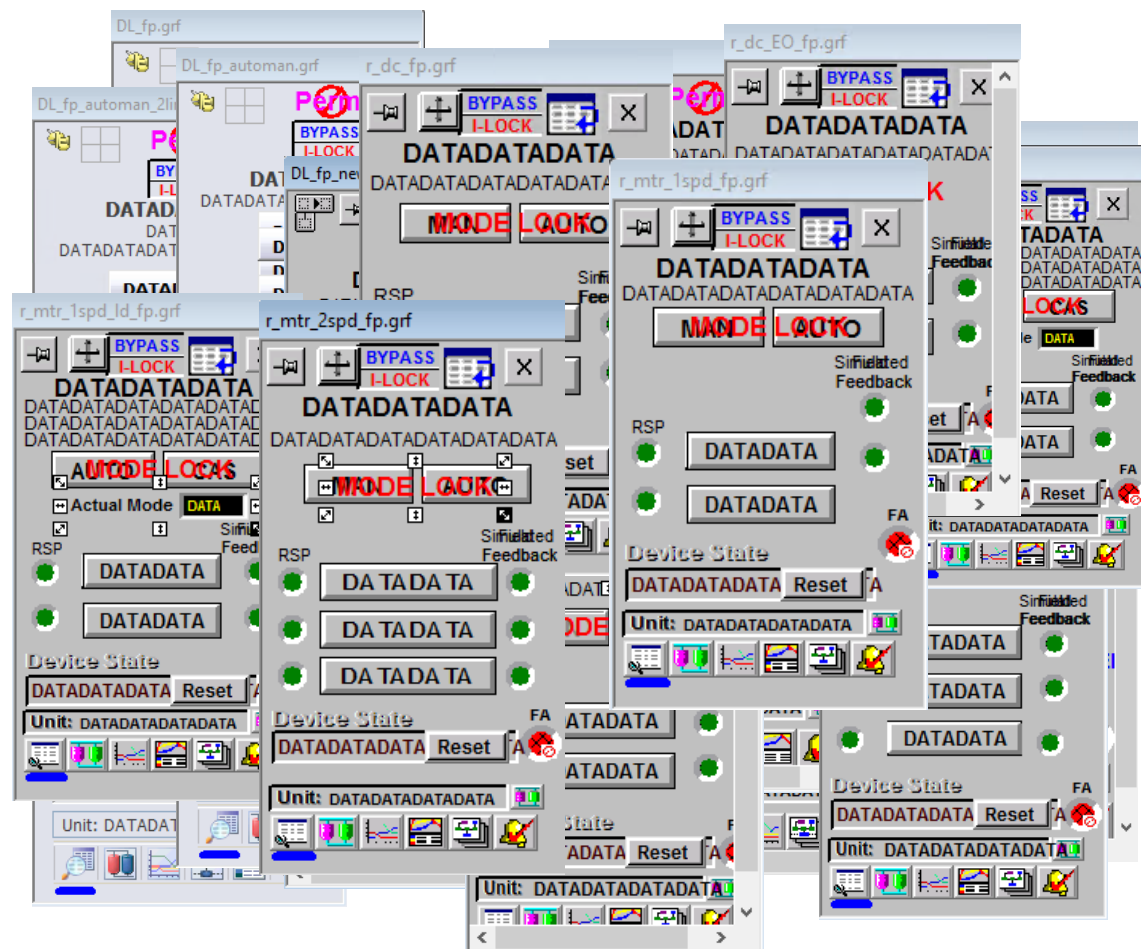

Human Centered Design

- Consistent DC detail displays created leveraging DLSYS.Exists function.

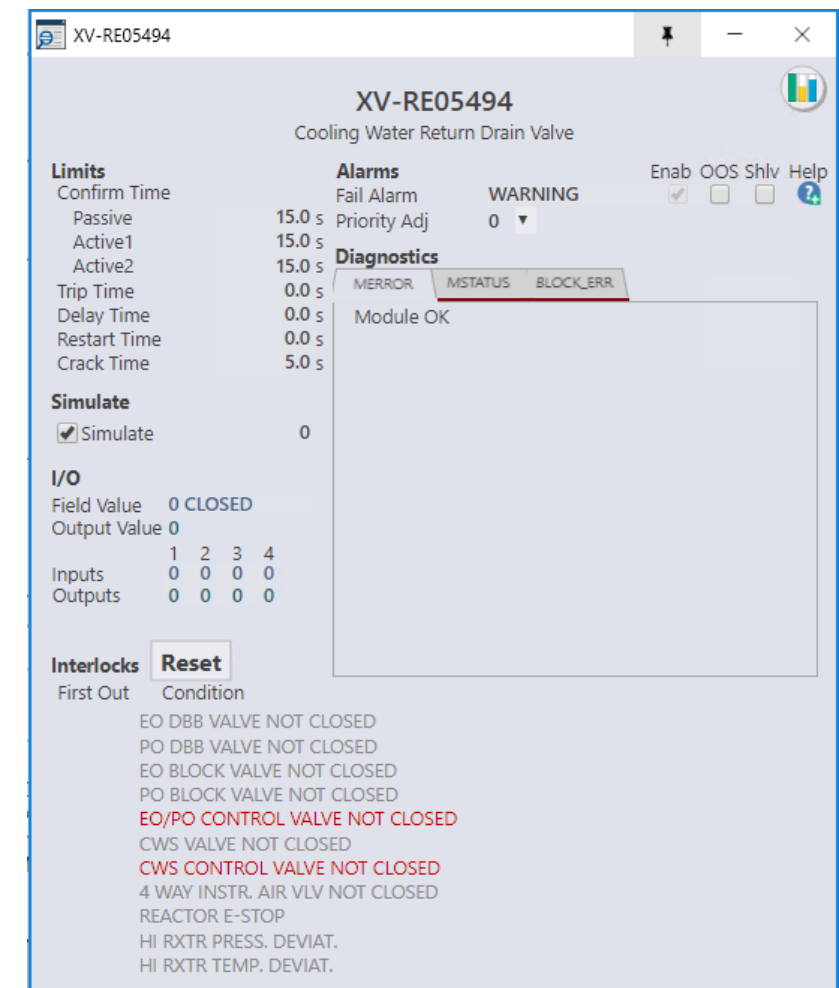
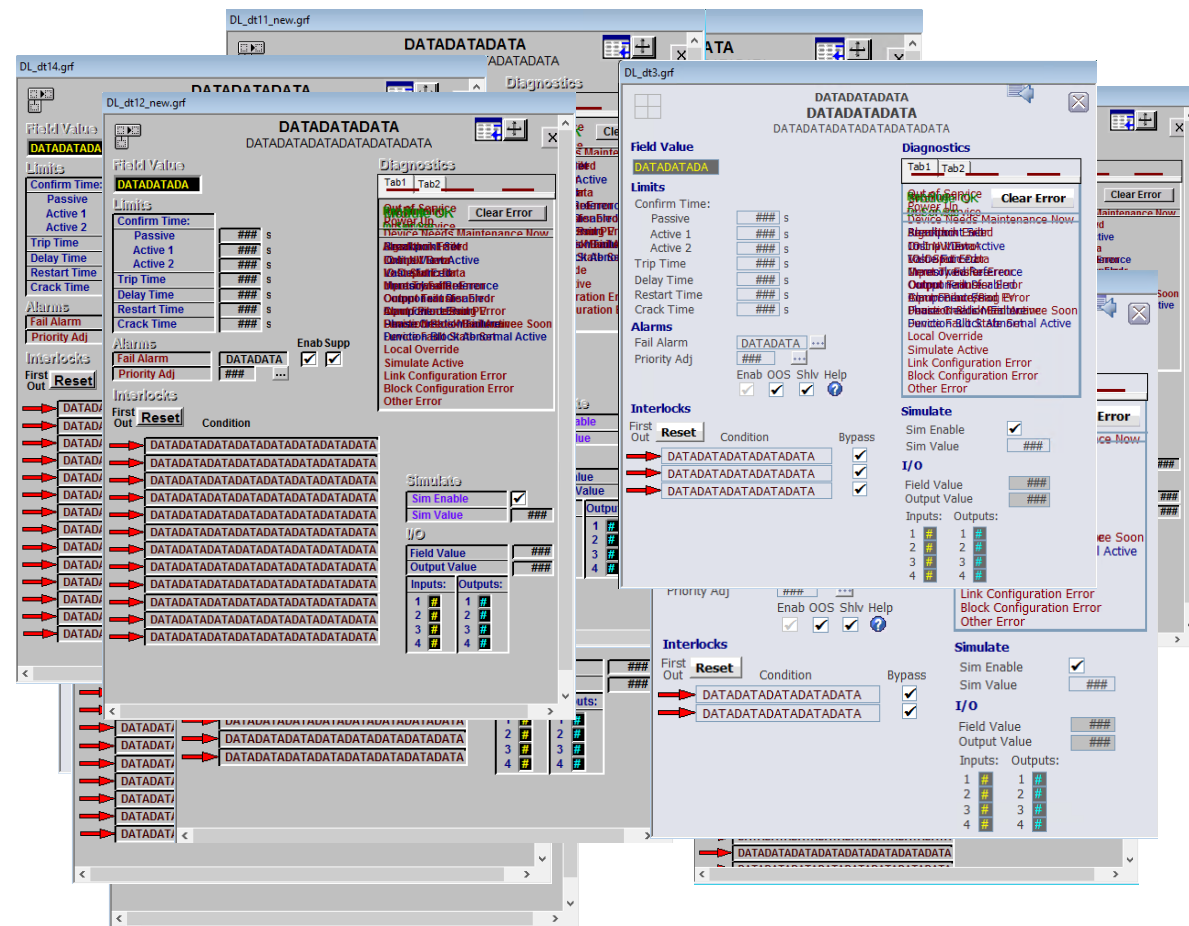

Human Centered Design

- Consistent **GEMs Library** created referencing function block parameters.

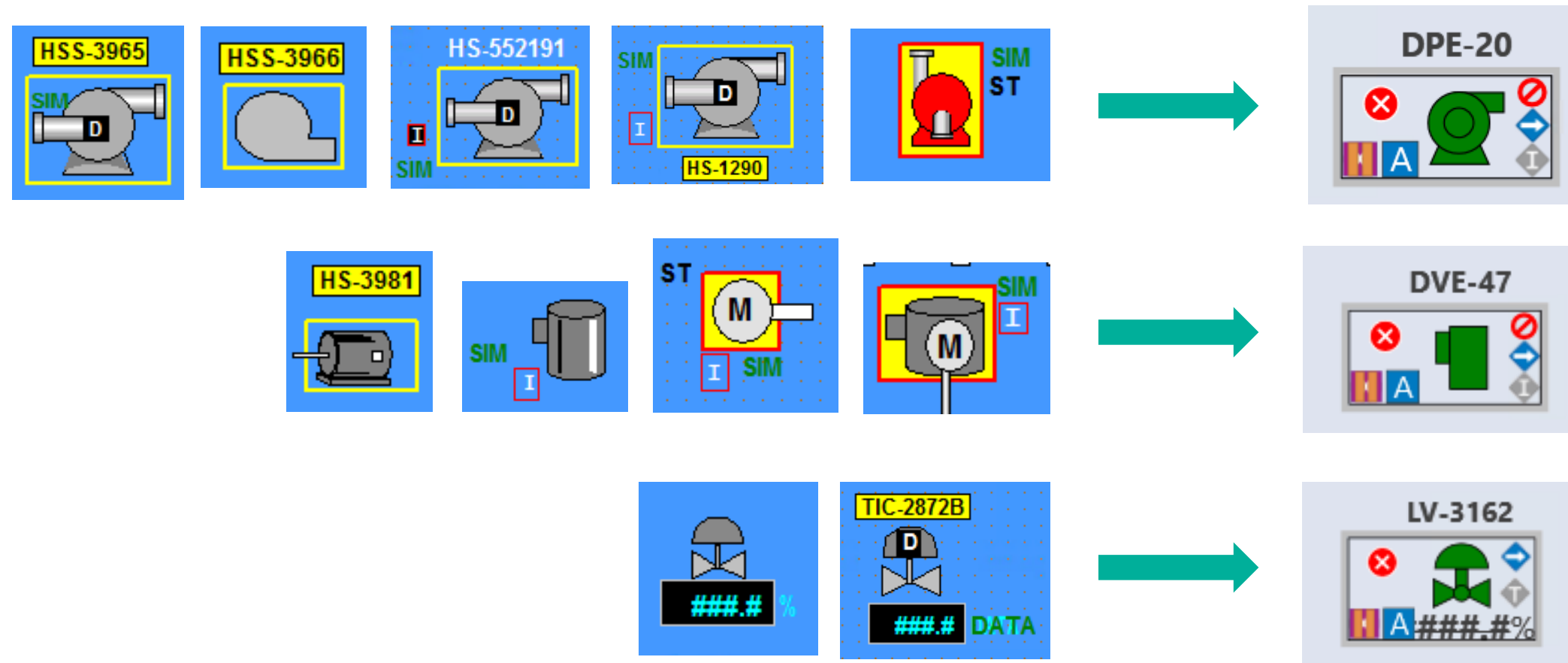

Human Centered Design

- High contrast **process lines** eliminated

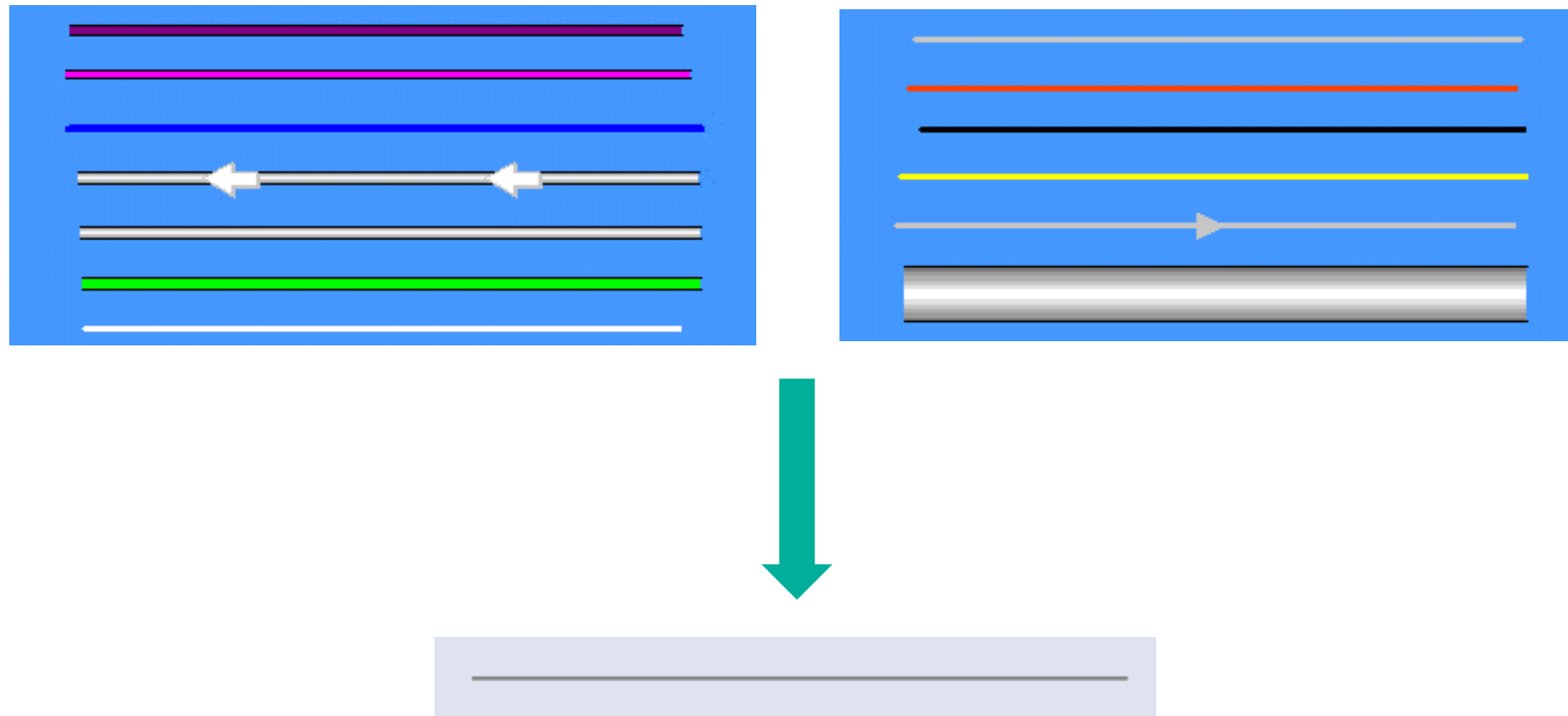

Human Centered Design

- High contrast process data eliminated

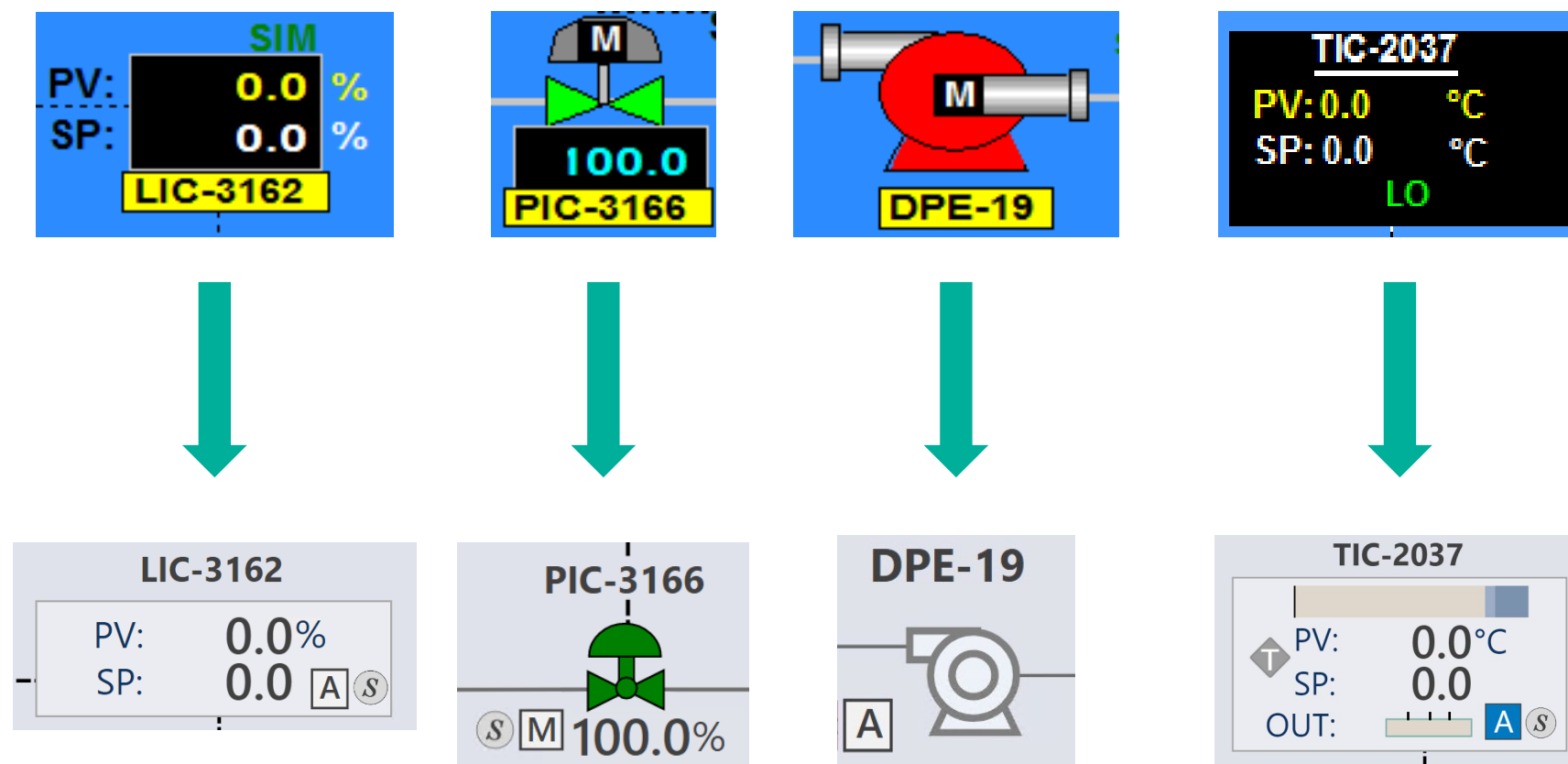

Human Centered Design

- Display Consistency Across Plant Areas:
 - Operators Can Easily Transition to Different Plant Areas
 - One GEM Library to Maintain Across Plant Areas

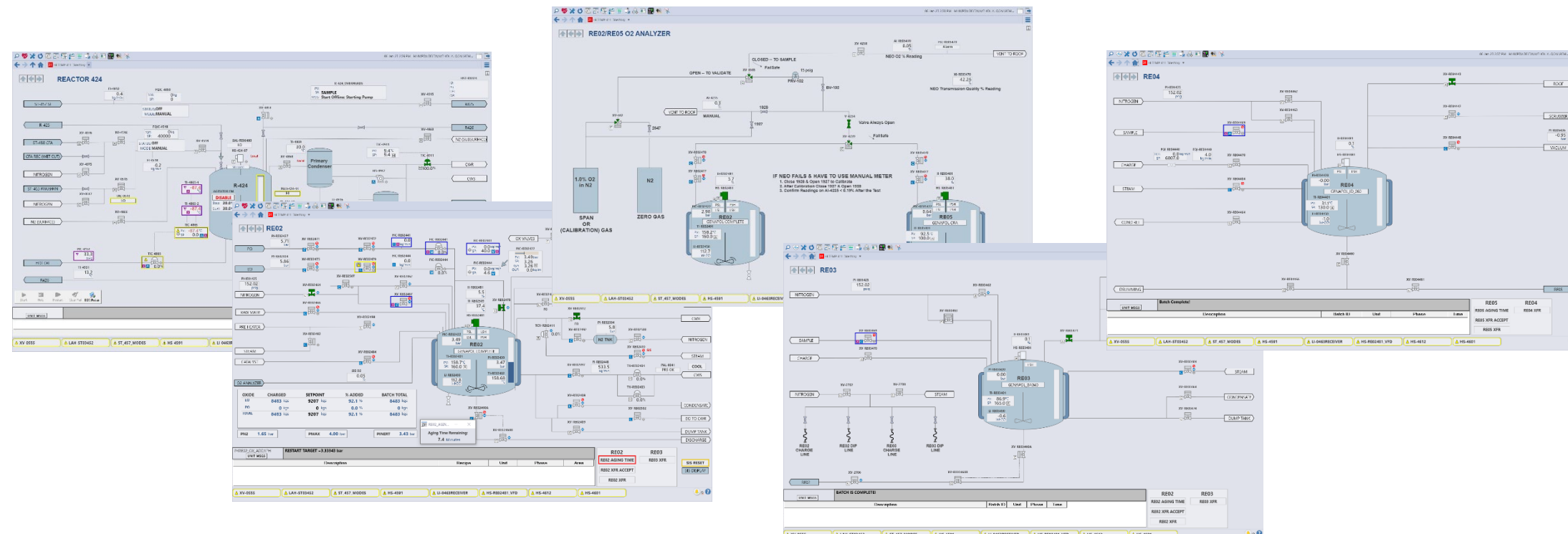

Human Centered Design

- Easier identification of alarms.

Where's Waldo?



Where are the Alarms?

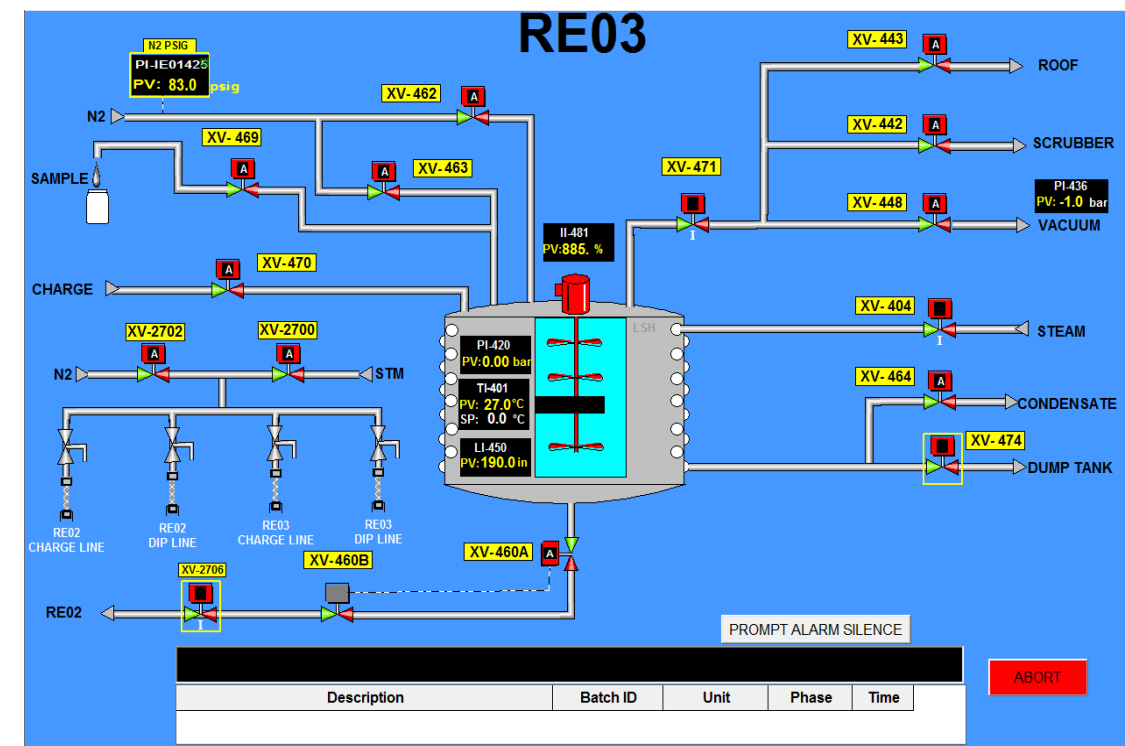

Human Centered Design

- Easier identification of alarms.

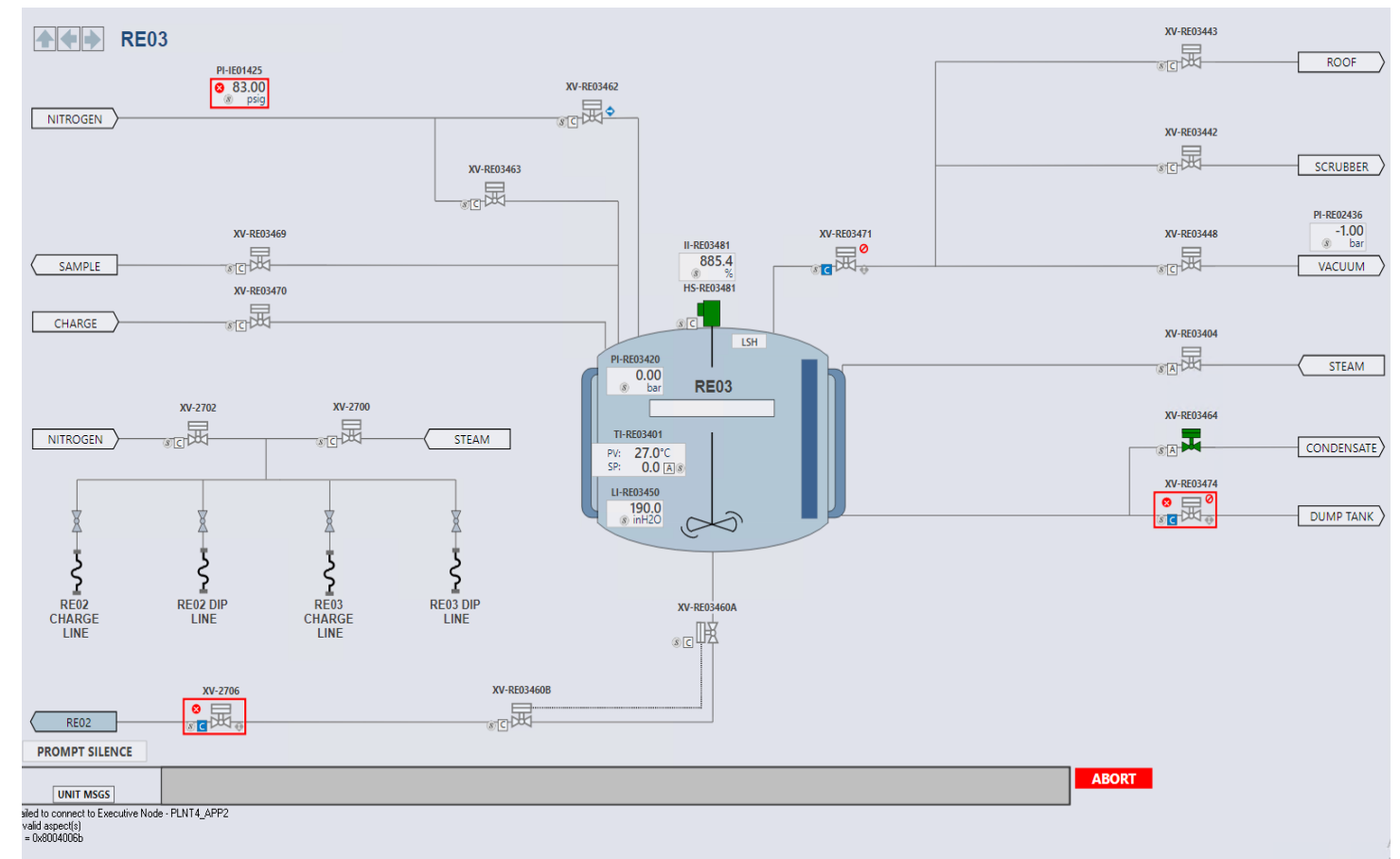
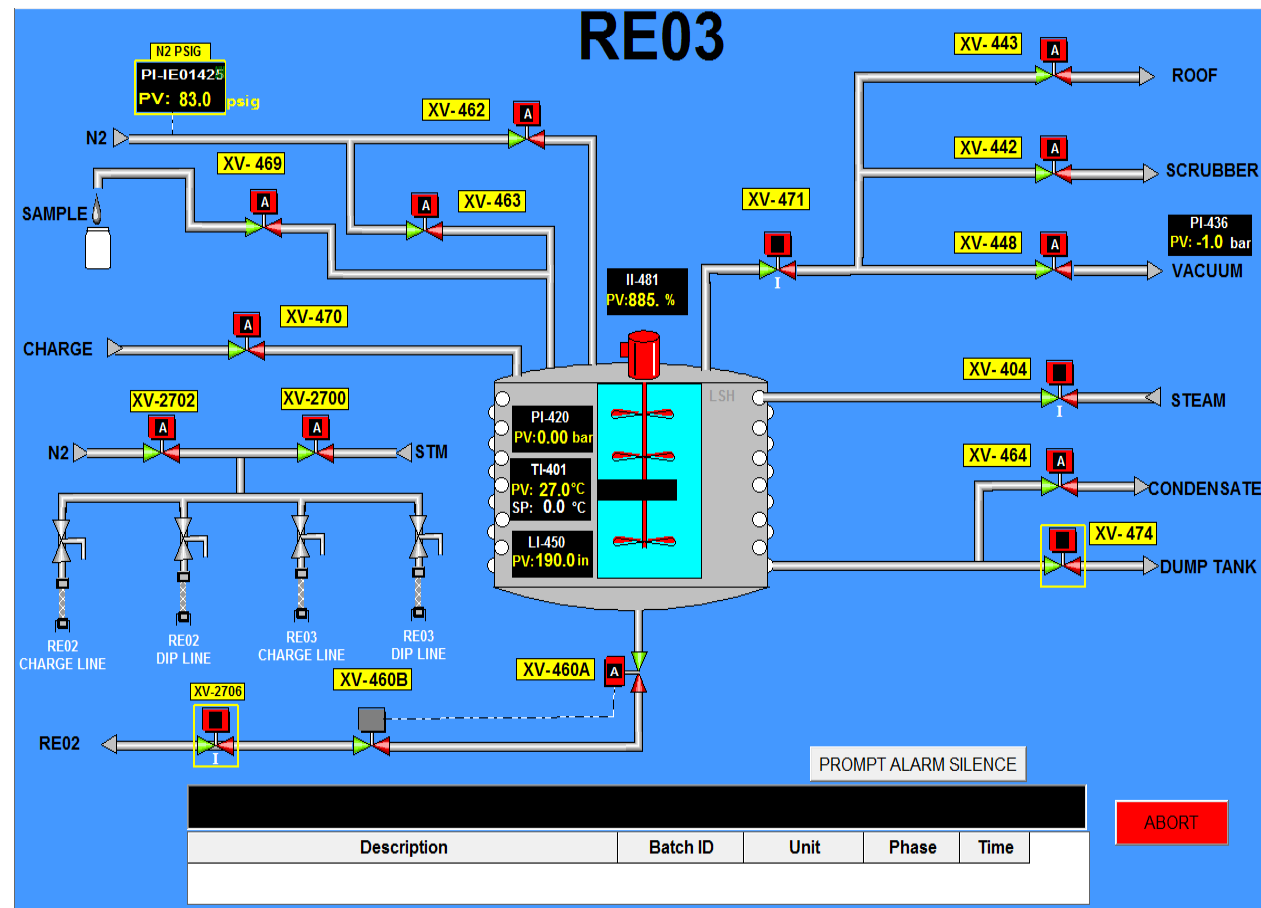

Display Navigation

State of the System

- No visual difference between a page link and a page reference:

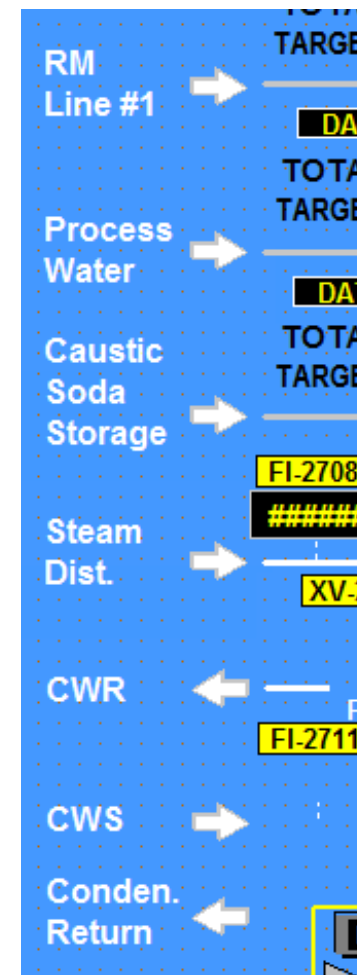
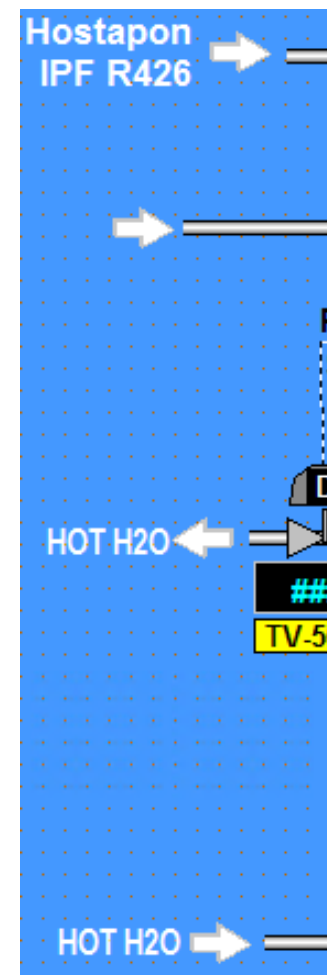
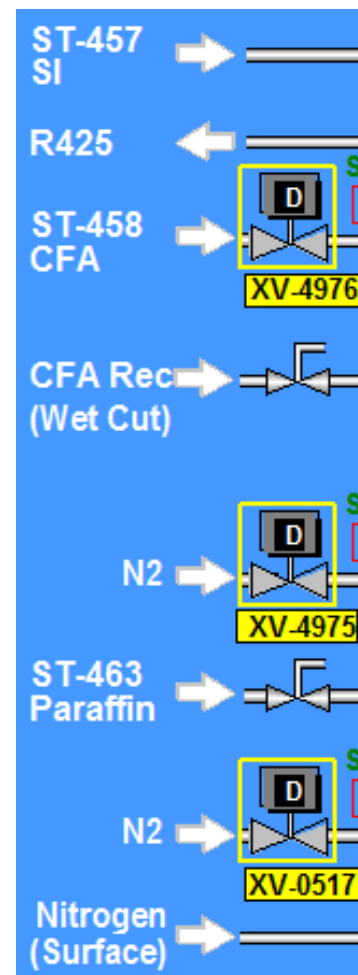
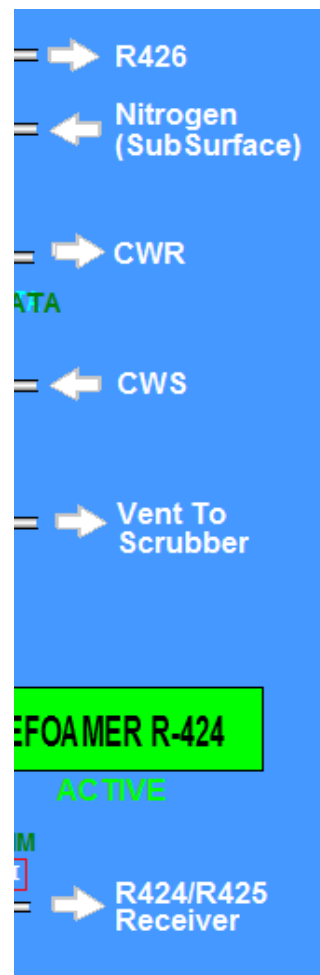

State of the System

- Instead of page links, the operators typically used overview displays to jump from display to display:

Plant 3 Menu

Raw Material Tanks	ST-381 & ST-382
Main Reactor, E-6	ST-372
Reactor Column, E-7	R315
Batch Column	R312
Product Tanks, E-25, E-30, E-37	R314
Waste Tanks	Receivers
Decanter & Caustic Tanks	R311
Neutralization Tank, R321	SIHI VAC PUMP
Deet Utilities	Flaking Equipment
Valve & Pump Status	Cooling Belt Water
Plant3 Sewer Sump	Chillers
MTA RECOVERY TANK	SCI Scrubbers & Hot Oil
DEA Monitoring	

State of the System

- Similar to overviews, the Batch Operate Interface would consume a monitor in the control room.

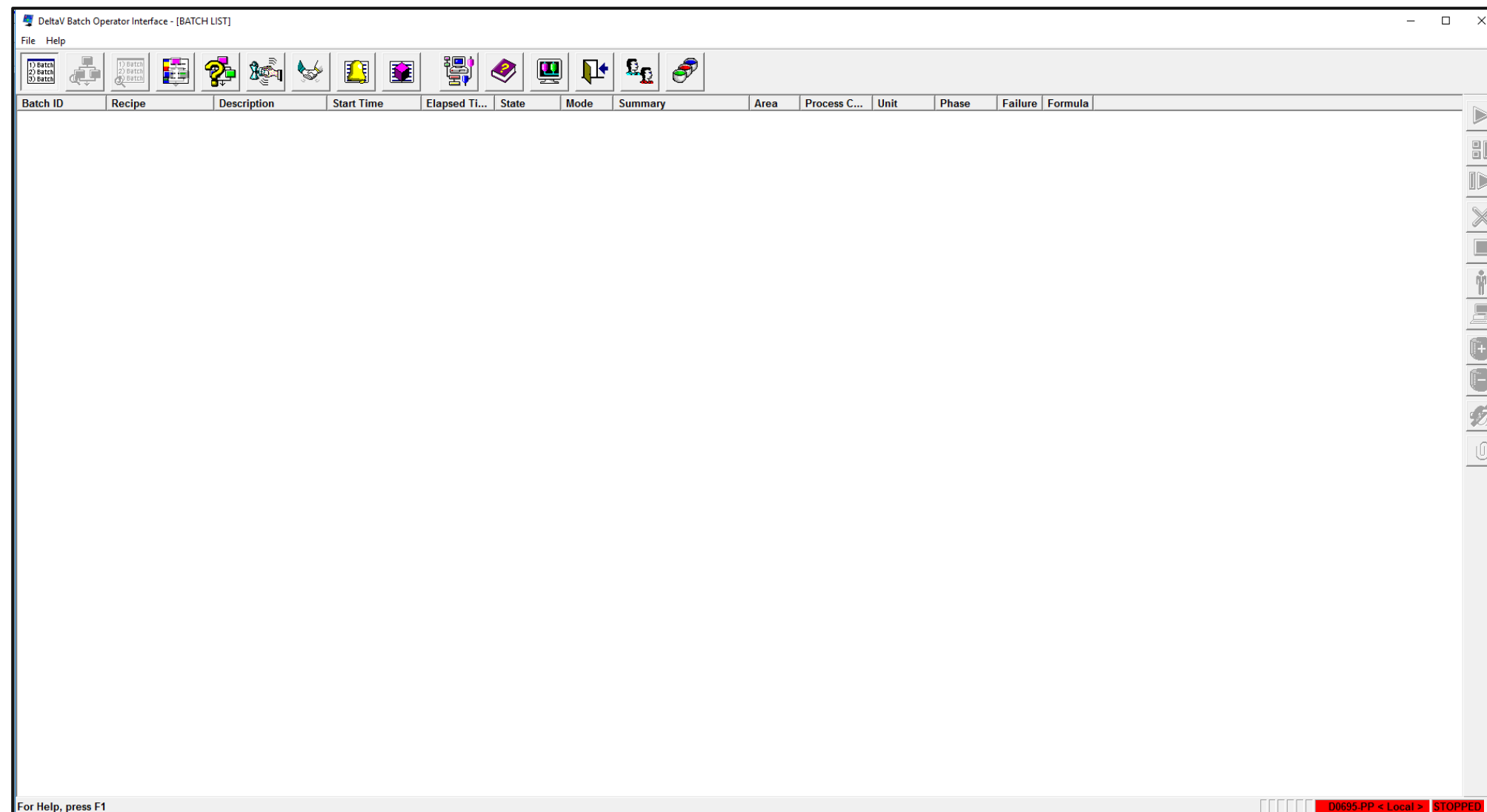

State of the System

- Quick links used on several graphics:

The image displays two process graphics for reactors R424 and R425. Each reactor is shown as a cylindrical vessel with a blue liquid level and a central agitator shaft. To the right of each reactor is a data box containing instrument information.

R424 Data:

- PI-424-10 SIM
- PV: ### DAT
- LI-424-09 SIM
- PV: ### DAT

R425 Data:

- PI-425-10 SIM
- PV: ### DAT
- LI-425-09 SIM
- PV: ### DAT

At the bottom of the graphics area is a table of quick links:

RX-422	RX-424	RX-425	RX-426	Raw Mat	Scrub'r	Defoam	Valves
AX-422	AX-424	AX-425	RX-423	Storage	Hot Oil	Stm Jets	Motors

Page Links/Reference

- Updated page links to show references versus links.
- Cleaned up shortcut names.

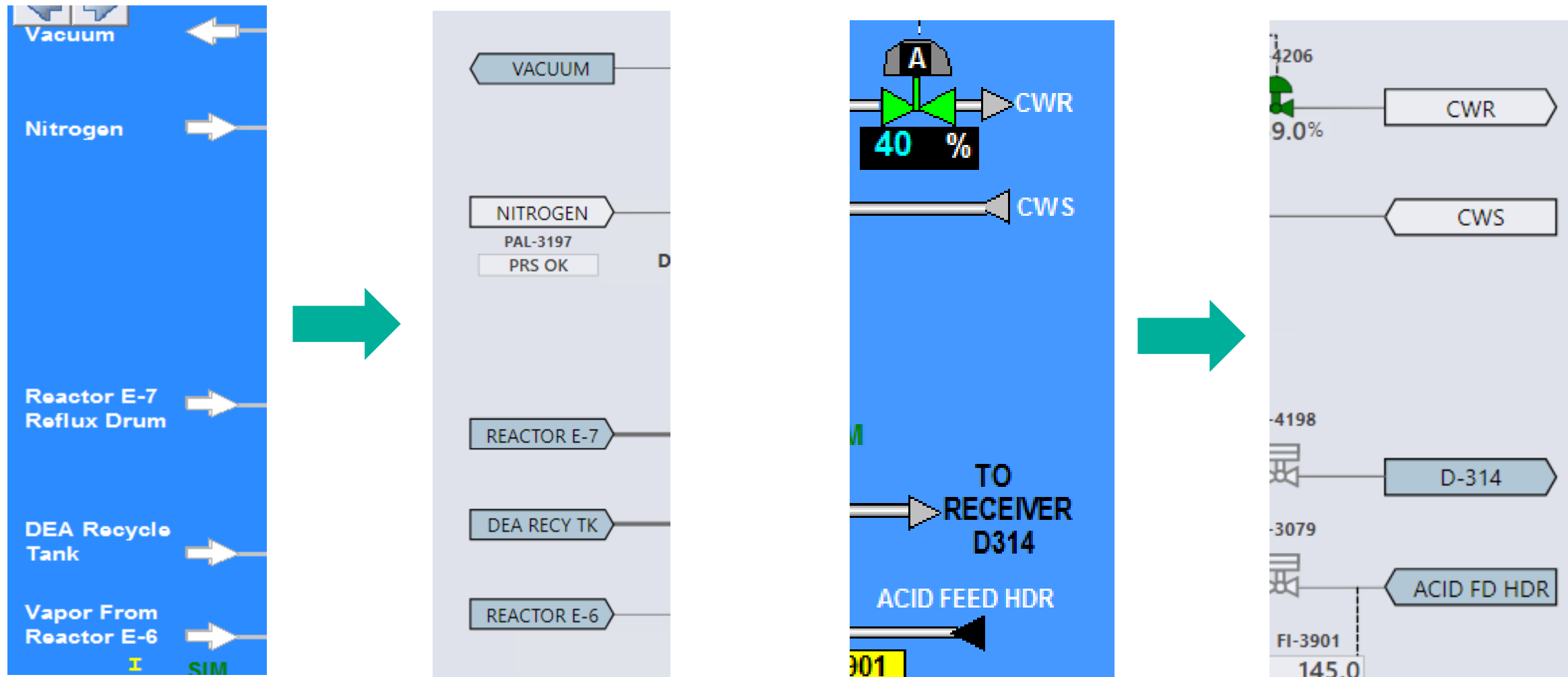

Display Set

- Provides the operator with quick access to all displays and alarm rollups:

RX-422	RX-424	RX-425	RX-426	Raw Mat	Scrub'r	Defoam	Valves
AX-422	AX-424	AX-425	RX-423	Storage	Hot Oil	Stm Jets	Motors

Plant 3 Menu	
Raw Material Tanks	ST-381 & ST-382
Main Reactor, E-6	ST-372
Reactor Column, E-7	R315
Batch Column	R312
Product Tanks, E-25, E-30, E-37	R314
Waste Tanks	Receivers
Decanter & Caustic Tanks	R311
Neutralization Tank, R321	SIHI VAC PUMP
Deet Utilities	Flaking Equipment
Valve & Pump Status	Cooling Belt Water
Plant3 Sewer Sump	Chillers
MTA RECOVERY TANK	SCI Scrubbers & Hot Oil
DEA Monitoring	



The screenshot shows the DEET Overview interface. At the top, there is a navigation bar with icons for search, home, and other functions. Below the navigation bar, there are two tabs: "39 DEET OVERVIEW" and "49 SCI OVERVIEW". A dropdown menu is open, showing a list of equipment items with colored indicators (purple, red, yellow) next to them:

- 1 ST381 & ST382
- ST372
- 17 R315
- 10 R312
- 3 R314
- Receivers
- 6 R311
- 3 SIHI Vacuum Pump
- 9 Flaking Equipment
- Cooling Belt Water
- Chillers
- SCI Scrubbers & Hot Oil
- Raw Materials
- R315 SIS Page 1

Below the menu, there are several large buttons for navigation: "Raw Material", "Main Reactor", "Reactor Column", and "Batch Column".

Display Sets

- Display sets created for each area to enhance operator display navigation:

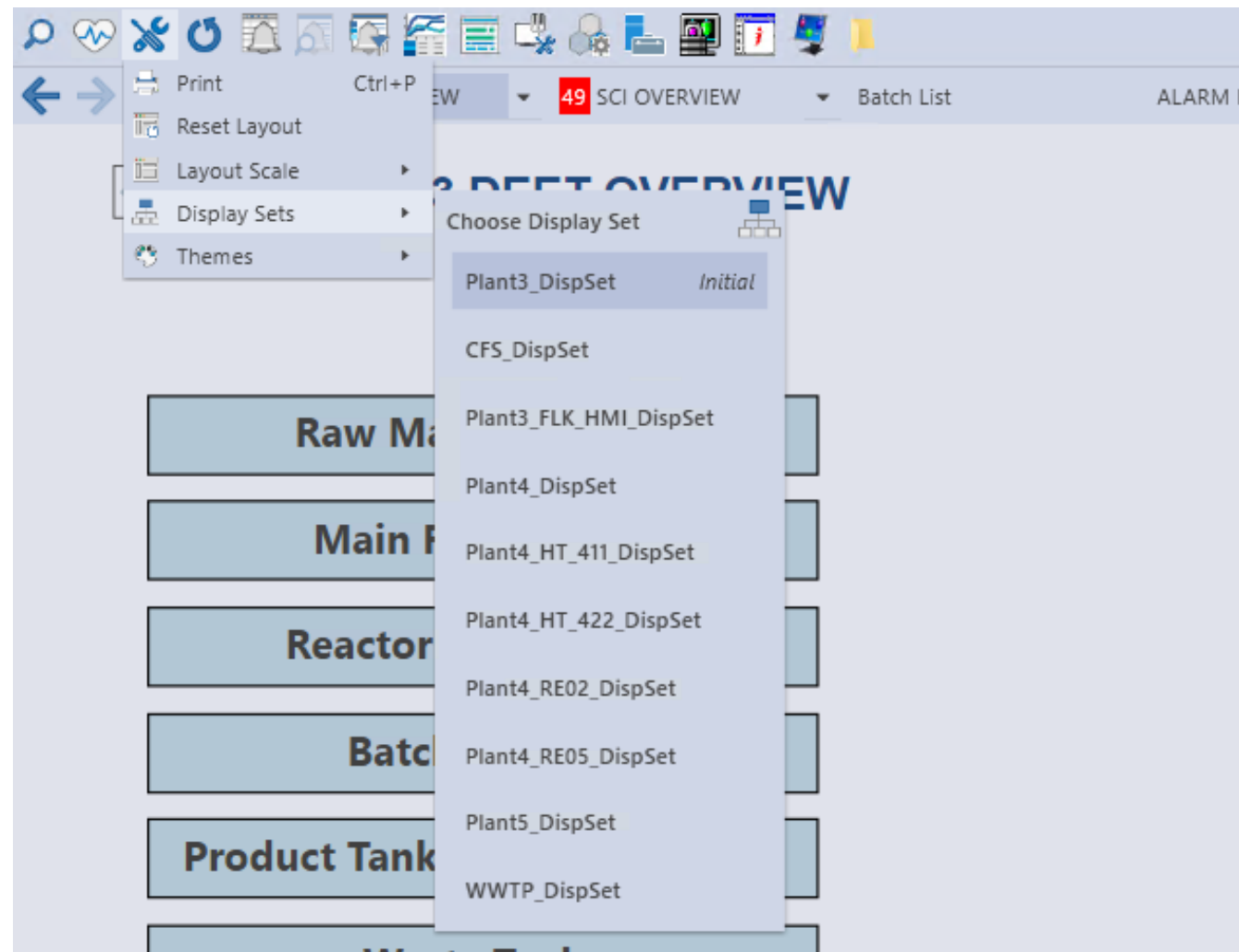

Overviews

- Replaced Batch Operator Interface with integrated batch overview displays:

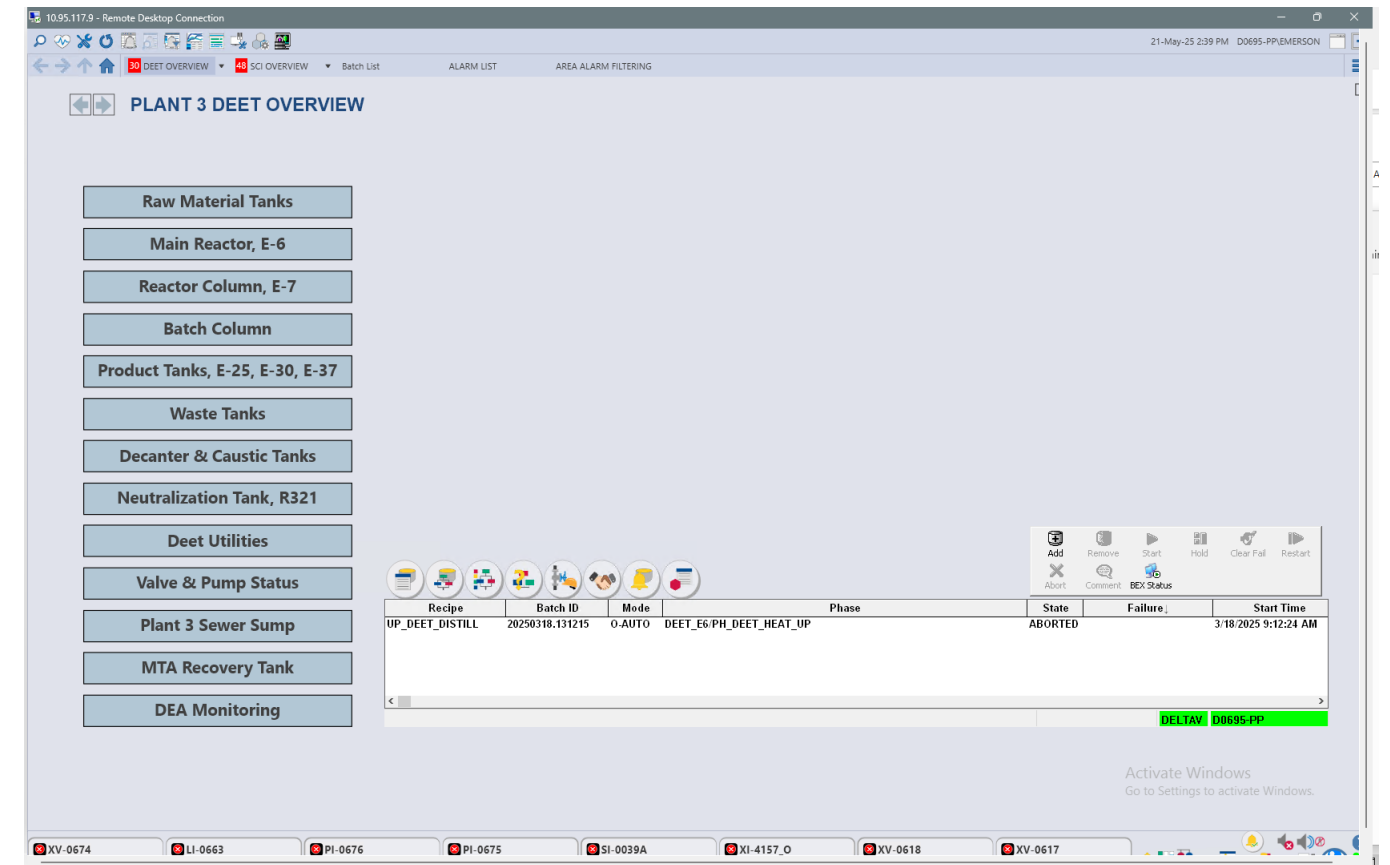
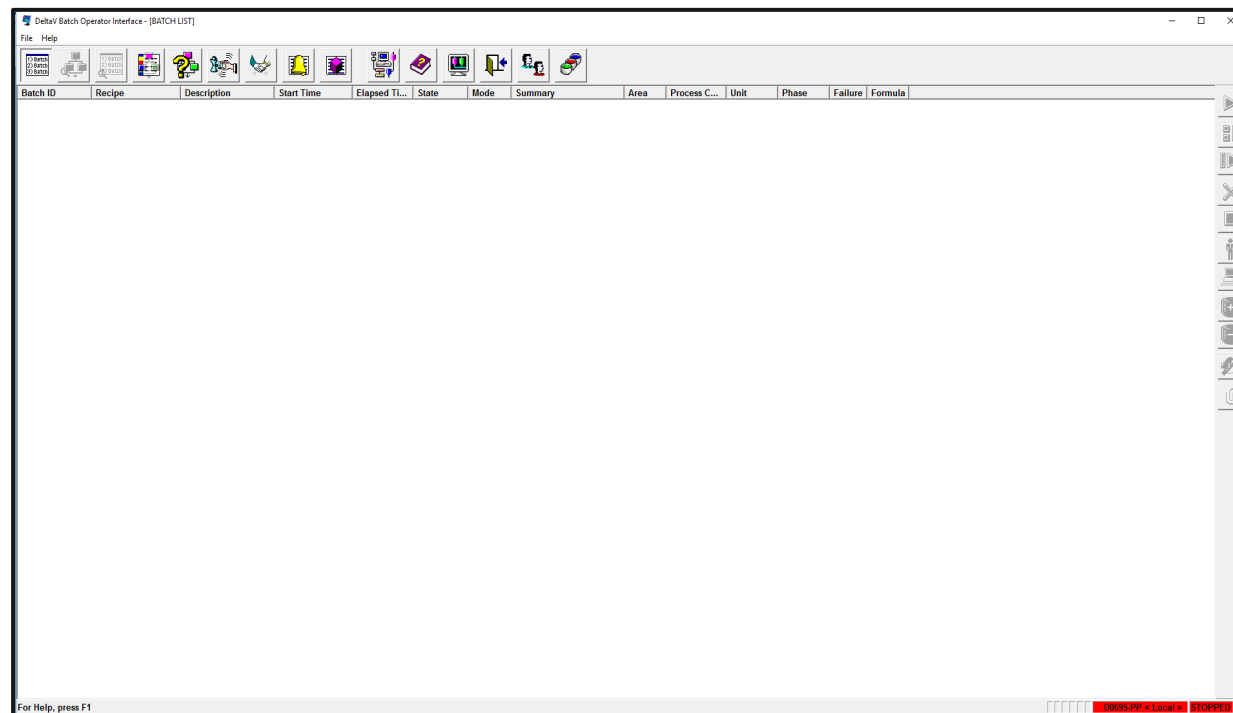

Overviews

- Replaced Batch Operator Interface with integrated batch overview displays:

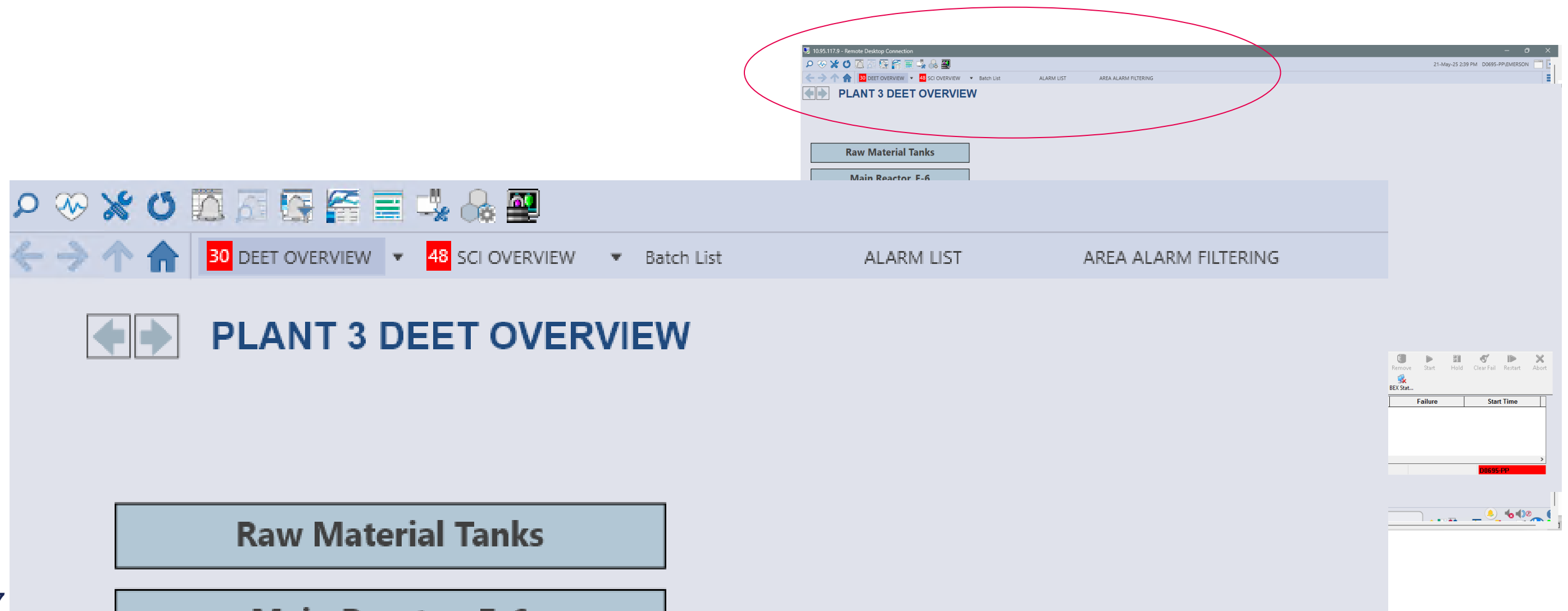

Watch Areas and Mini Faceplates

Monitoring Devices (Faceplates)

- Ability to open more faceplates can lead to visibility issues with the process:

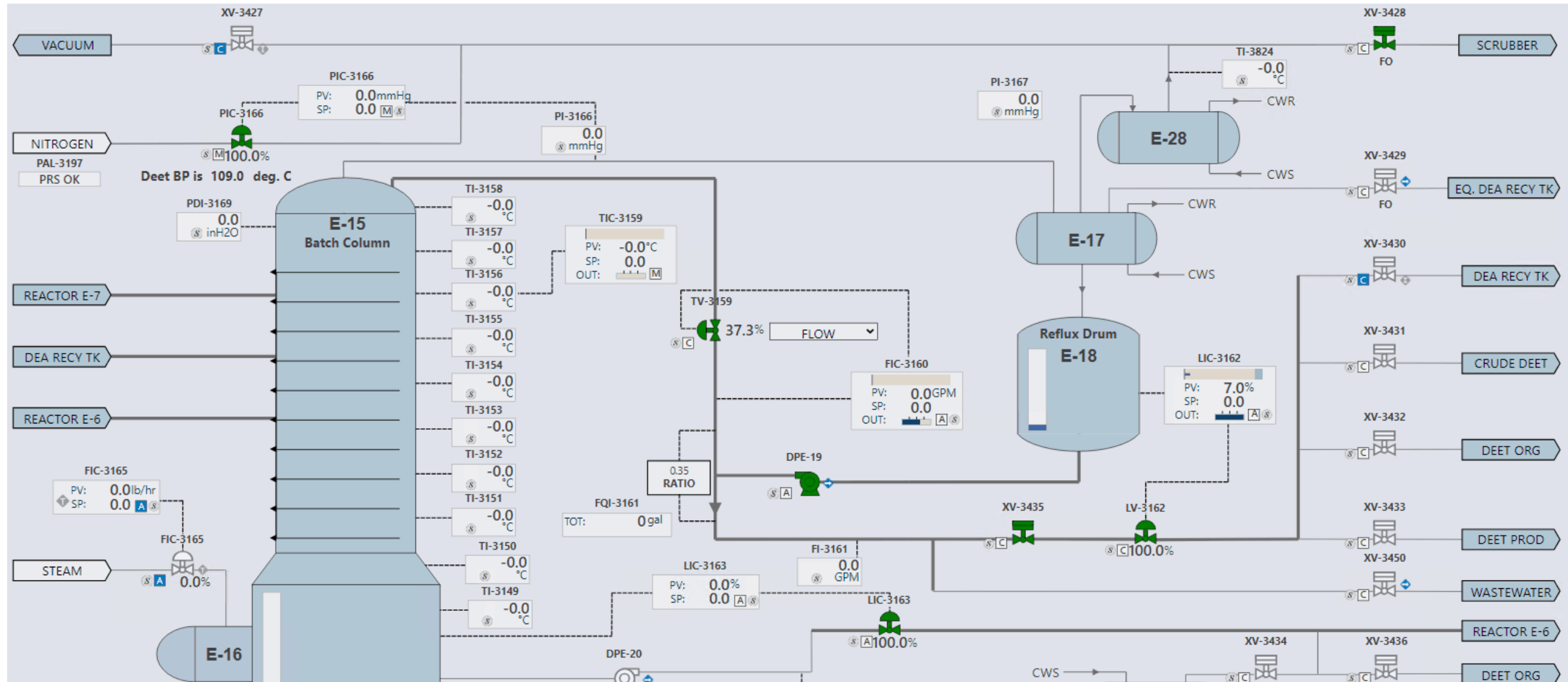

Monitoring Devices (Mini Faceplates)

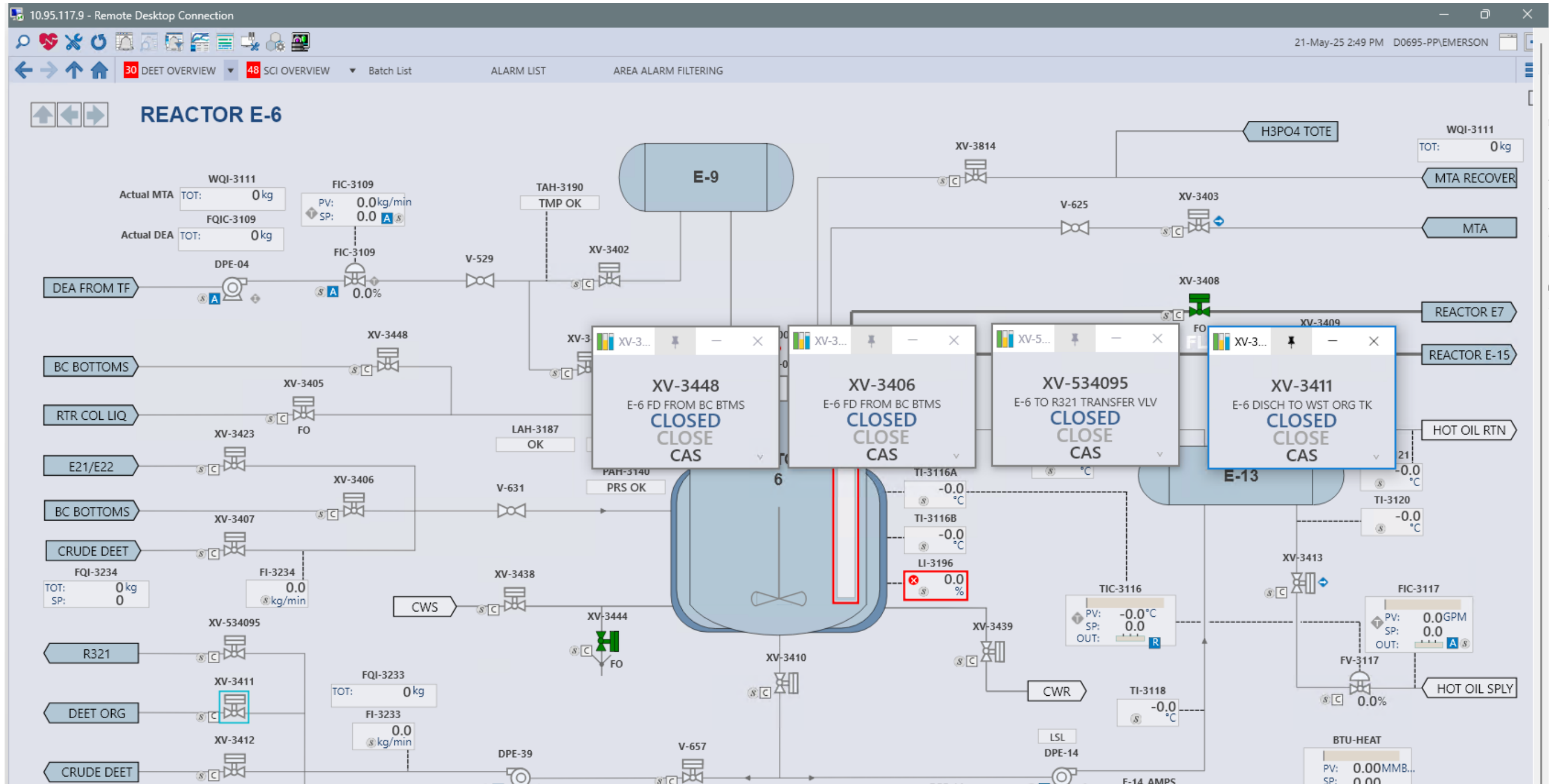

Monitoring Devices (Watch Areas)

- Created custom Watch Areas to allow viewing multiple process values in a single window:

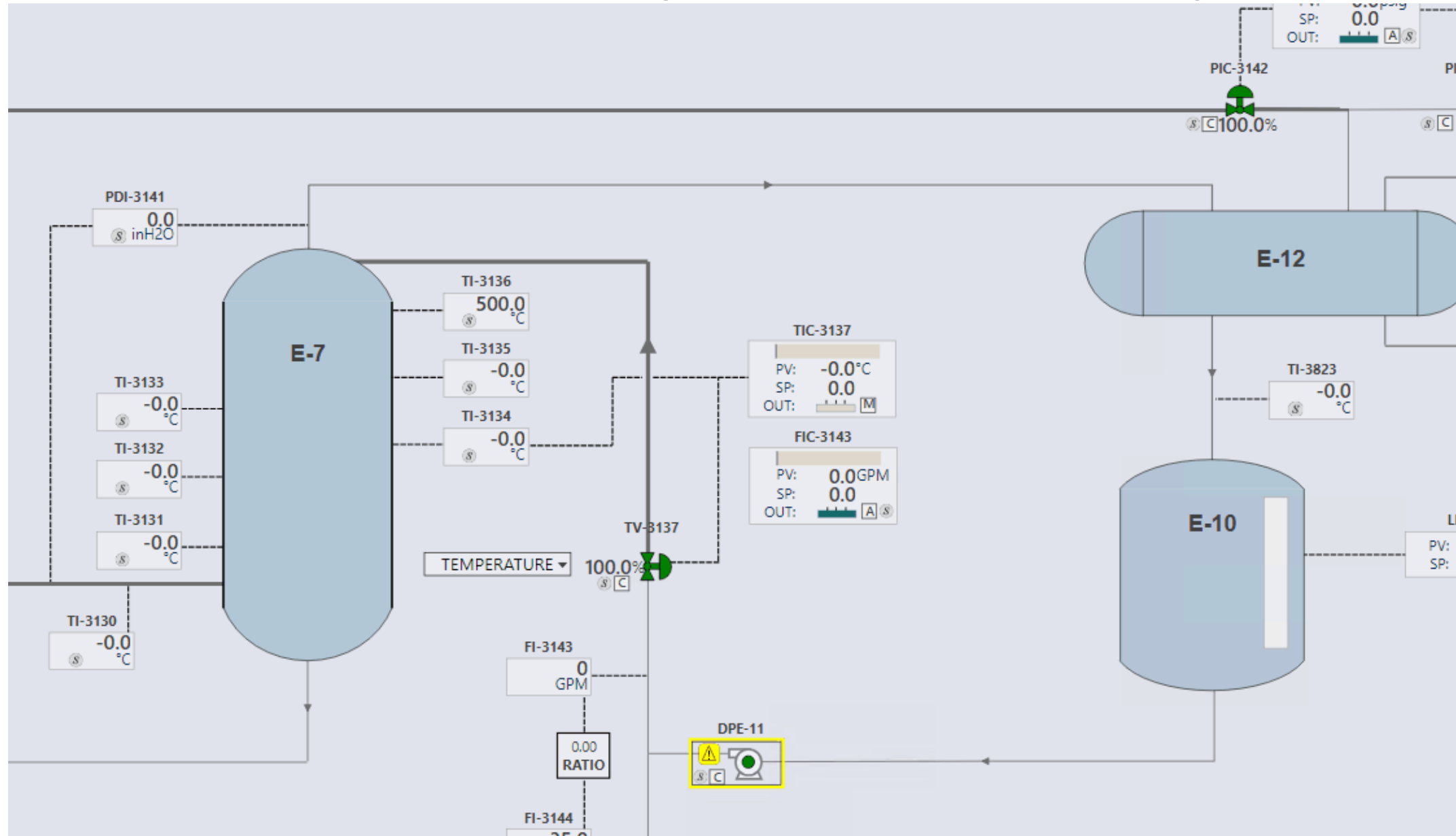

Watch Areas

- Created options for displaying the module tag and description if easier to identify:

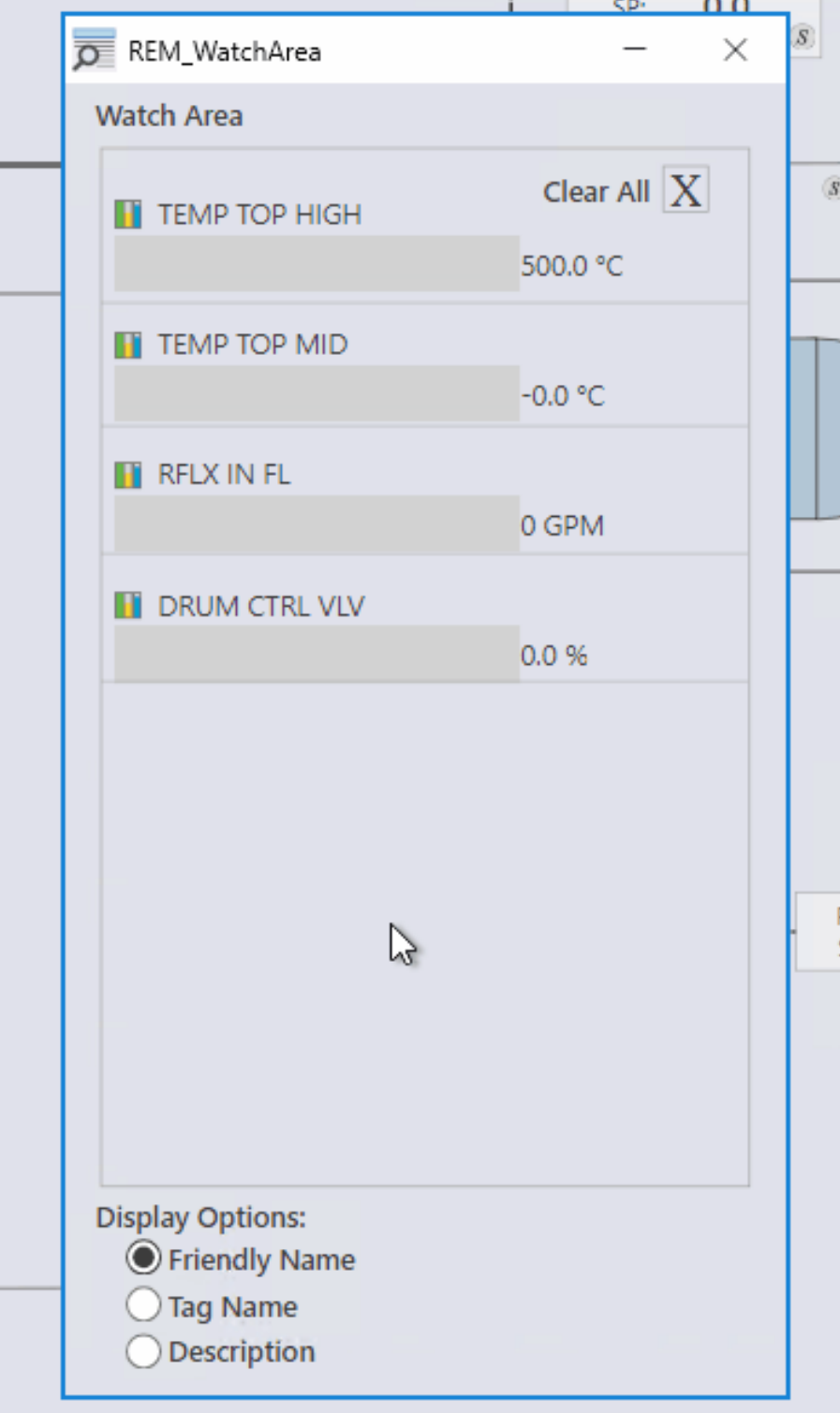

The screenshot shows a software window titled "REM_WatchArea" with a "Watch Area" section. It contains four rows of data, each with a small icon, a label, a value, and a unit. A "Clear All X" button is located at the top right of the list. Below the list is a "Display Options" section with three radio buttons: "Friendly Name" (selected), "Tag Name", and "Description".

Variable	Value	Unit
TEMP TOP HIGH	500.0	°C
TEMP TOP MID	-0.0	°C
RFLX IN FL	0	GPM
DRUM CTRL VLV	0.0	%

Display Options:
 Friendly Name
 Tag Name
 Description

High-Performance GEMs

State of the System

- Difficult to distinguish Simulation alert from module Units:

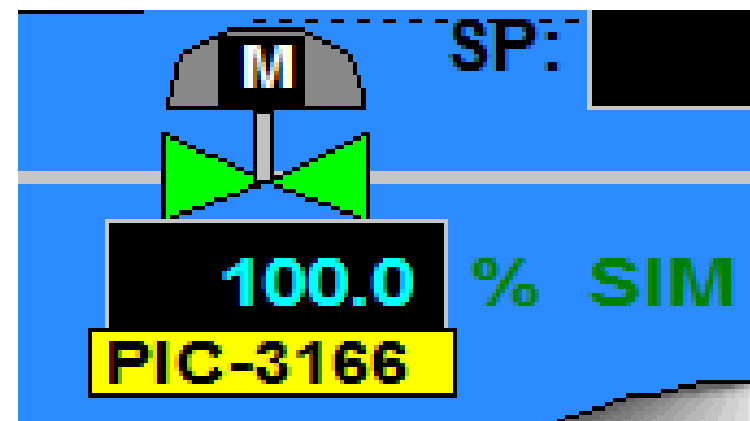

- No Mode displayed or abnormal mode indications:

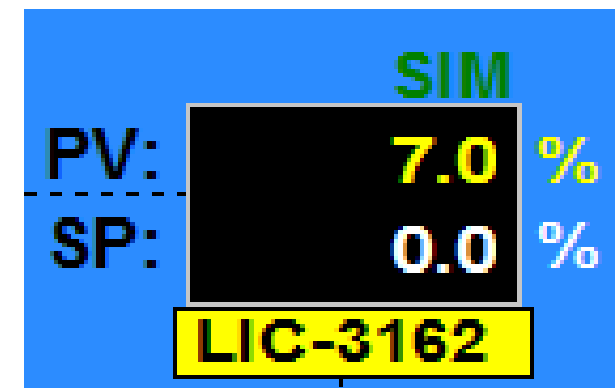
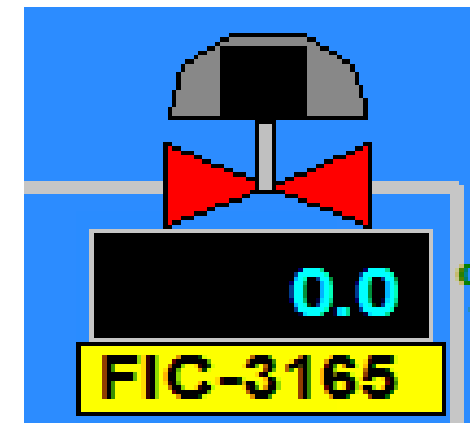

State of the System

- Difficult to recognize when a bypass condition was active:

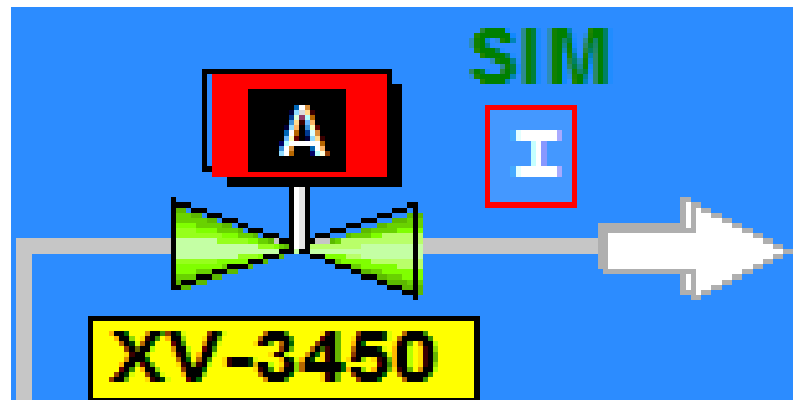

- At times unnecessary details included in dynamics:

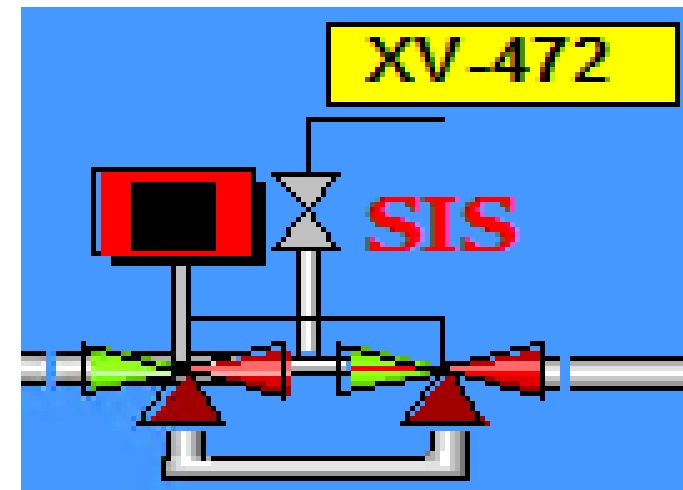

GEM Icons

- Difficult to distinguish Simulation alert from module Units:



State of the System

- No Mode displayed or abnormal mode indications:

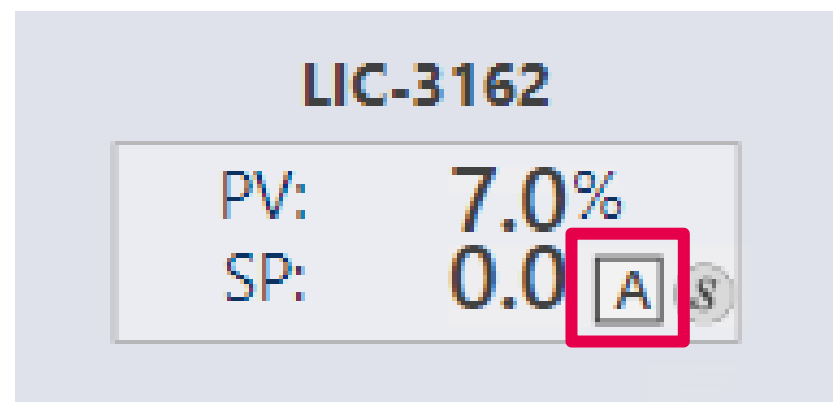
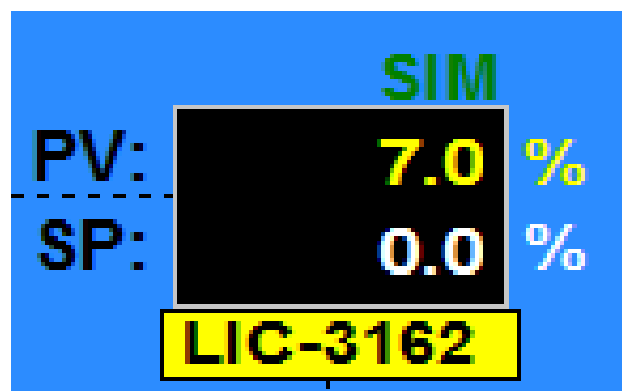
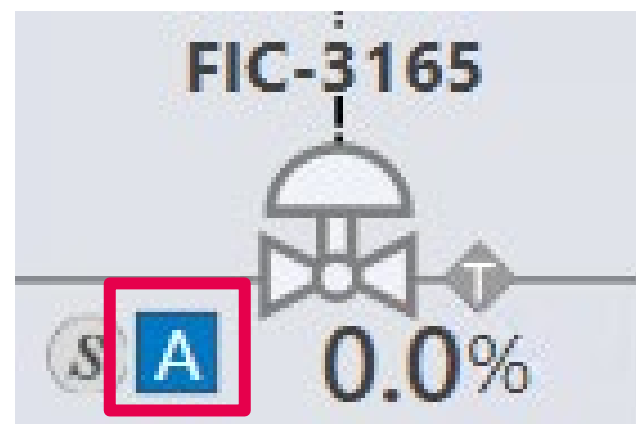
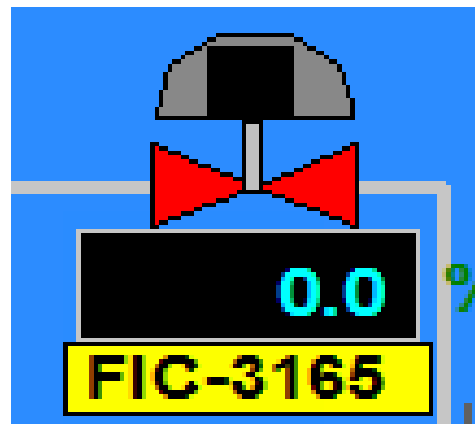

GEM Icons

- Created separate icons for Interlock and Bypass conditions:

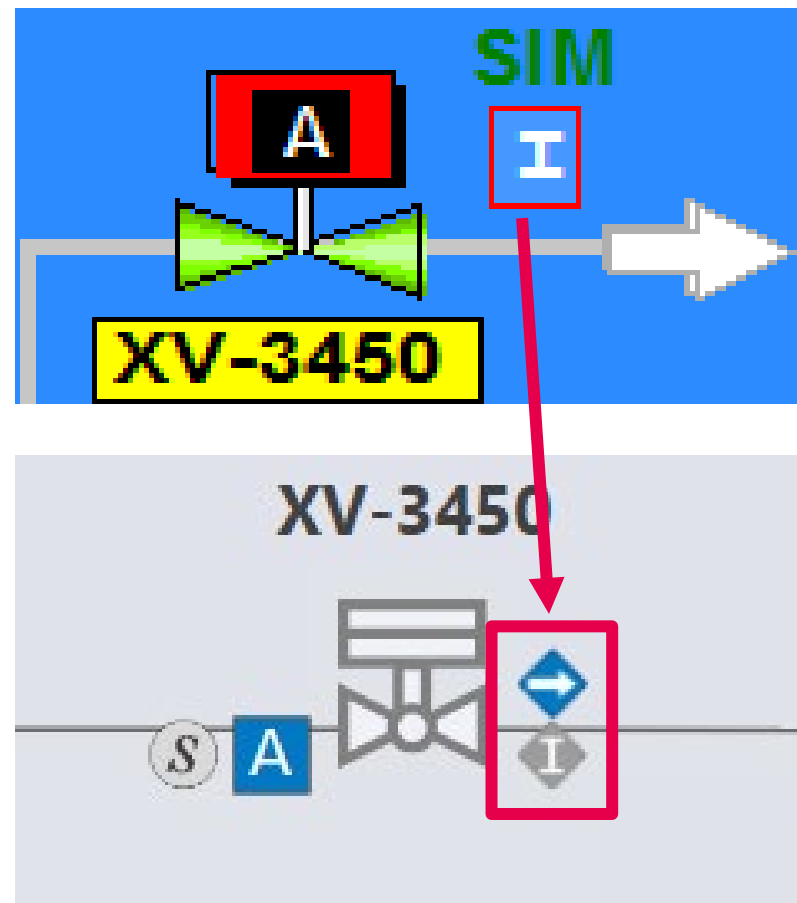

- Simplified unnecessarily complex dynamics and added helpful icons:

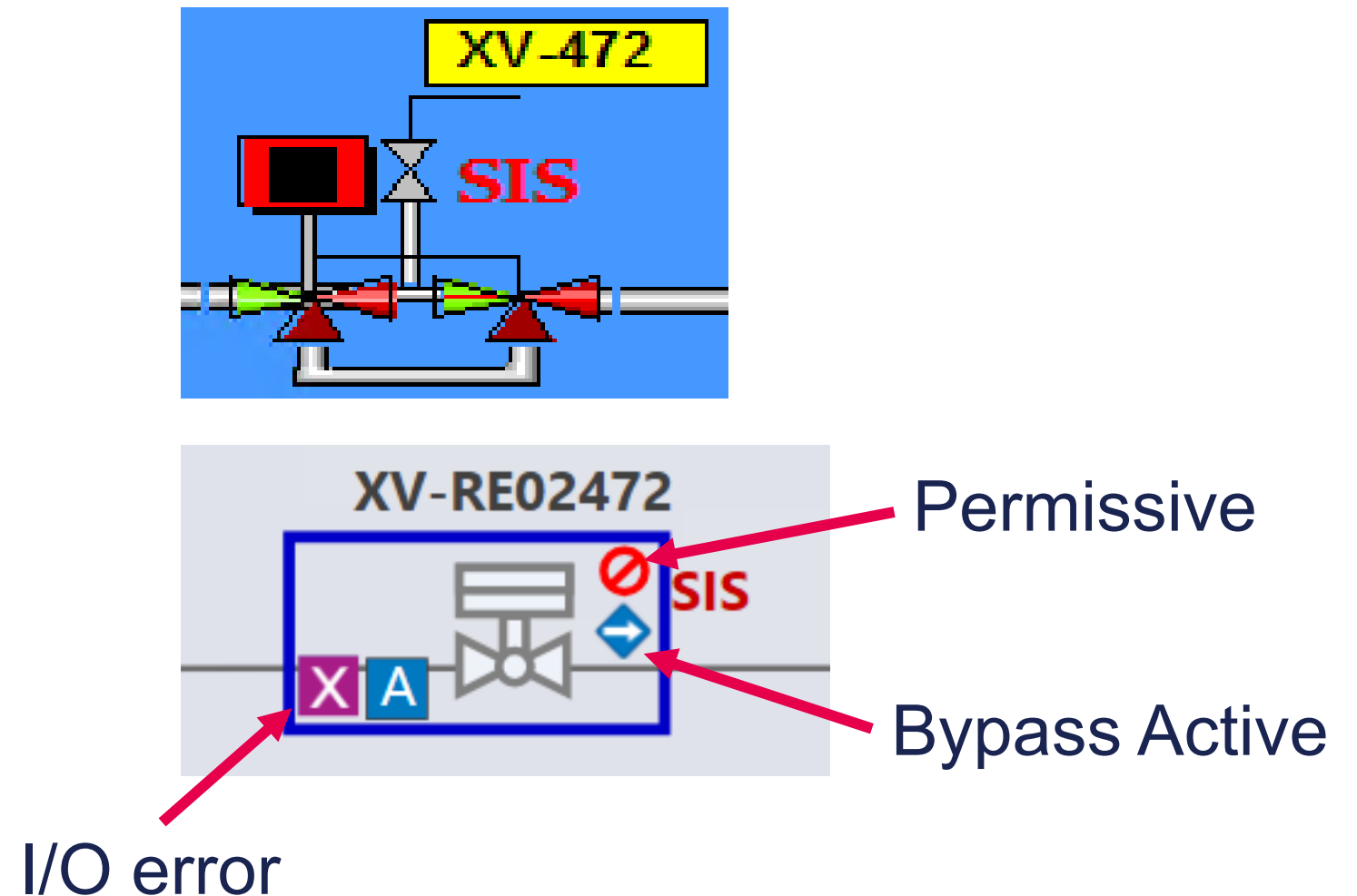

GEM Hotspots (Upgrade Enhancements)

- Added GEM hotspots to quickly identify which piece of equipment from an open faceplate:

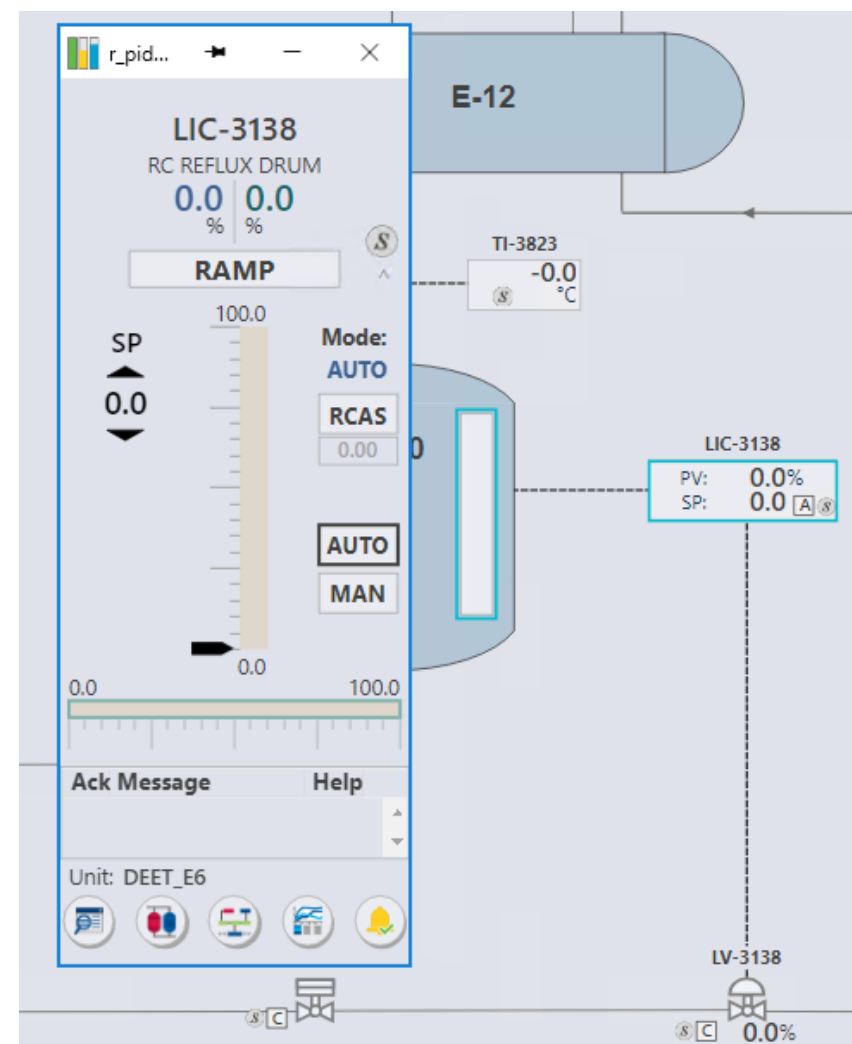
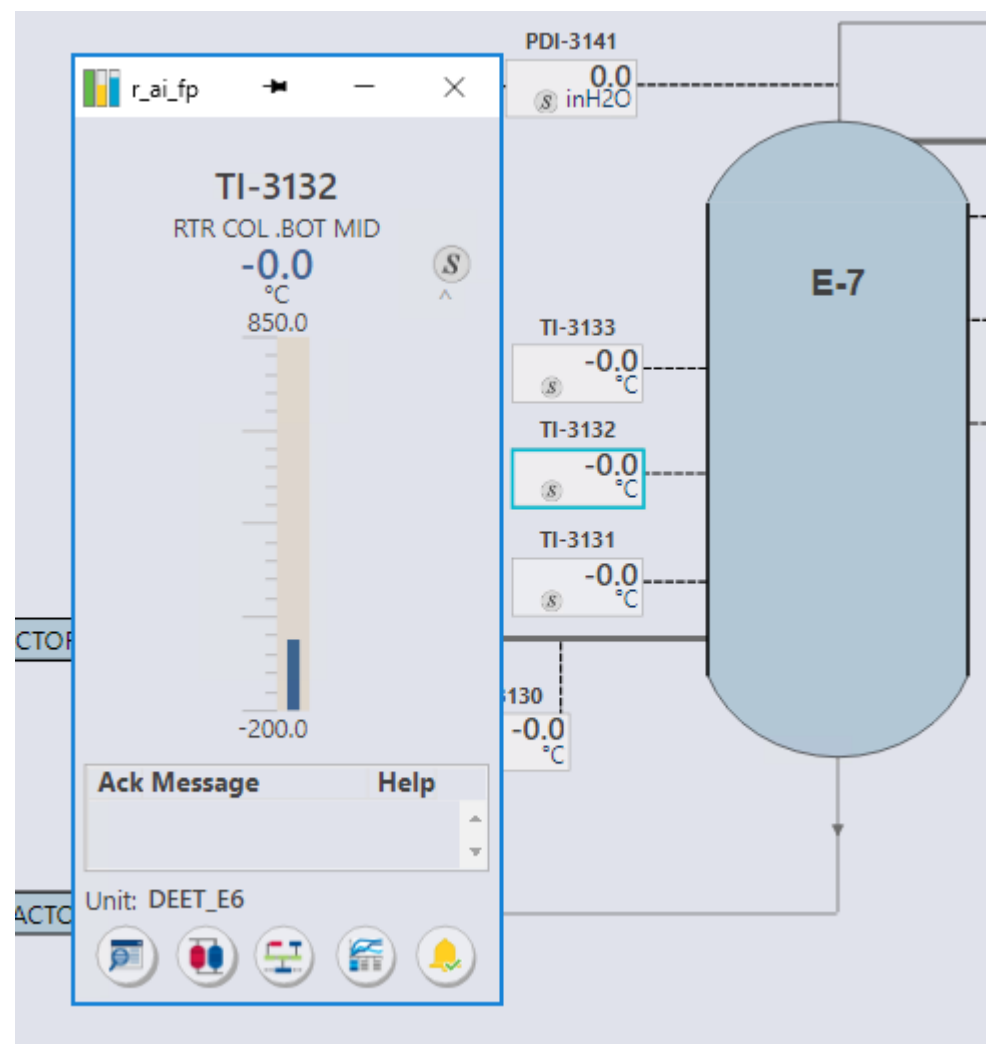

Text Resizing

- Added the ability to change the text size of process data for Operators:

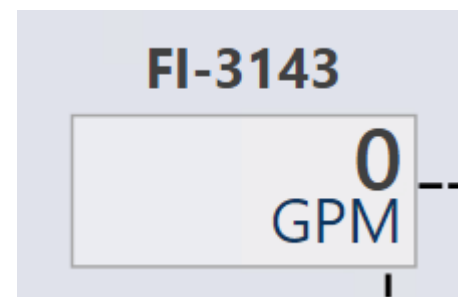
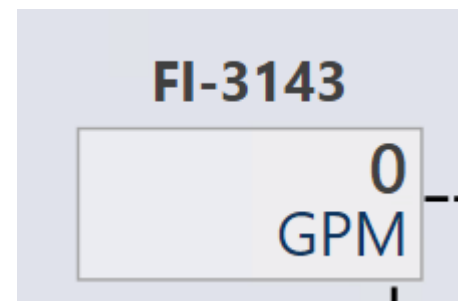
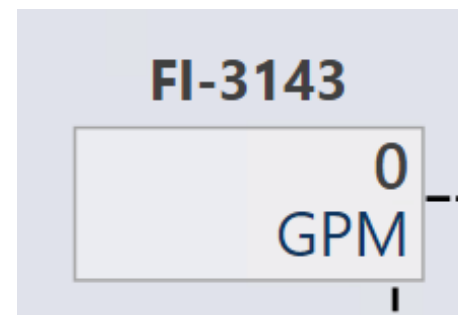
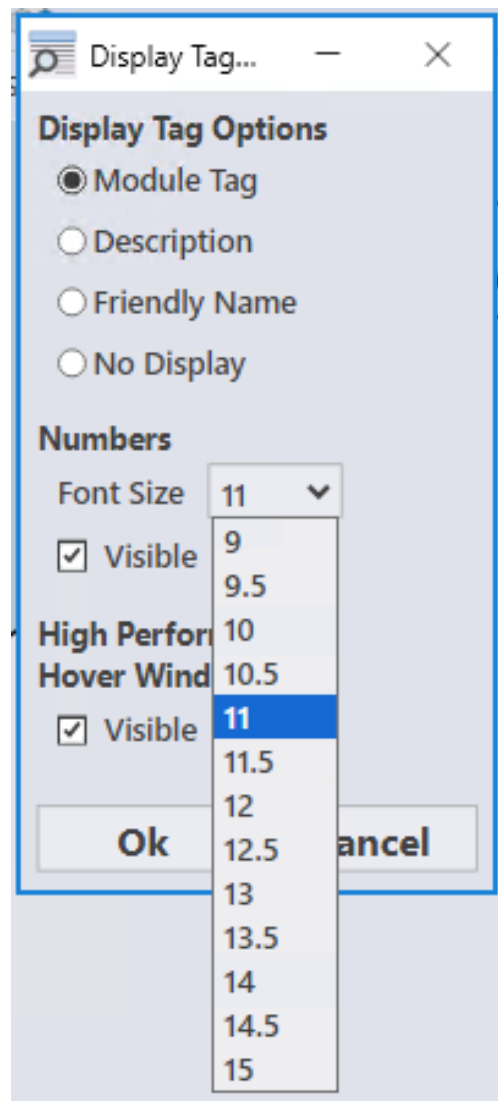

Quick Add to Chart Builder

- Right clicking on GEMs allows Operator to quickly add values to the chart builder.

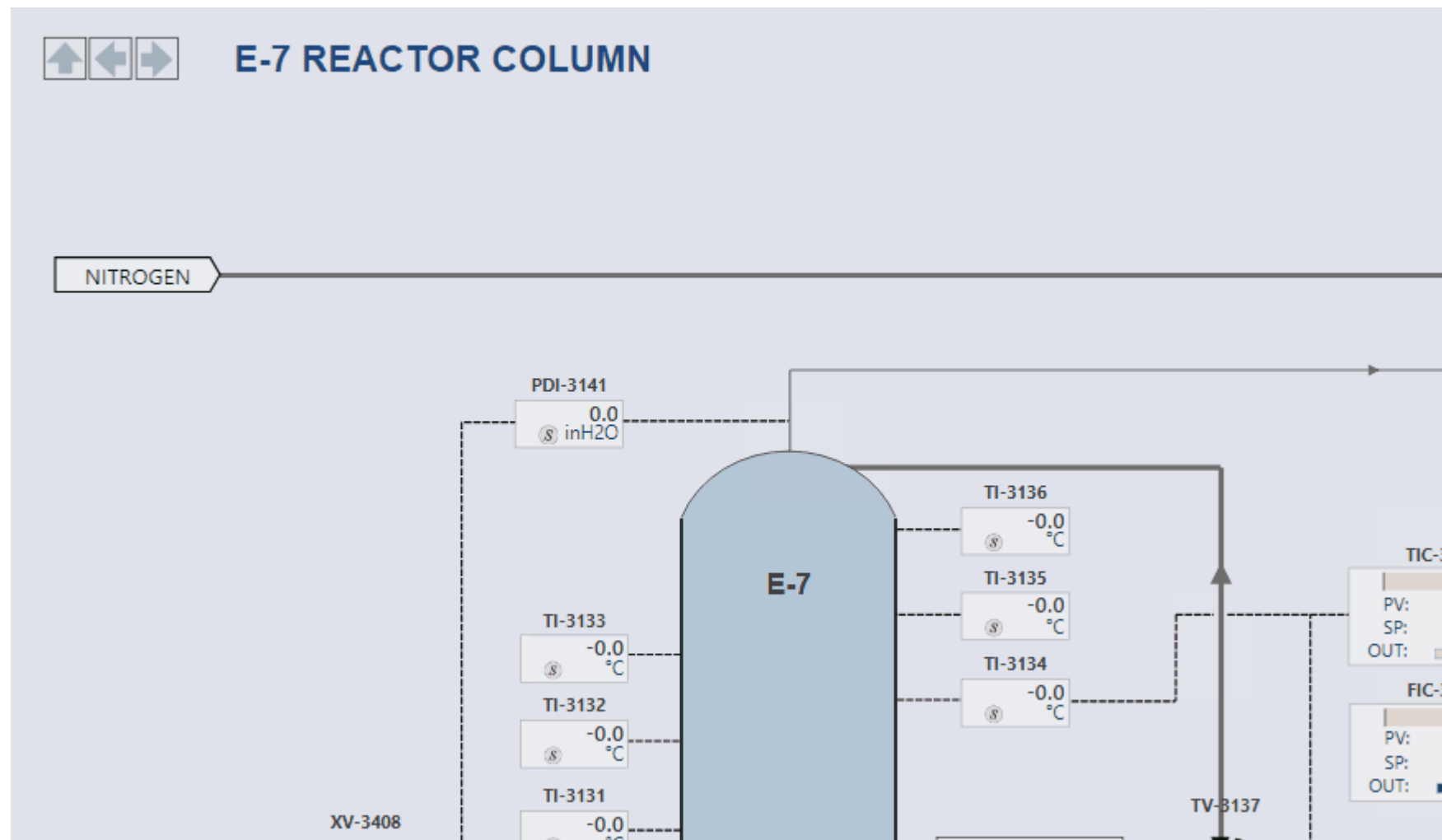

Friendly Names

- Configured “Friendly Names” to help with onboarding of new Operators:

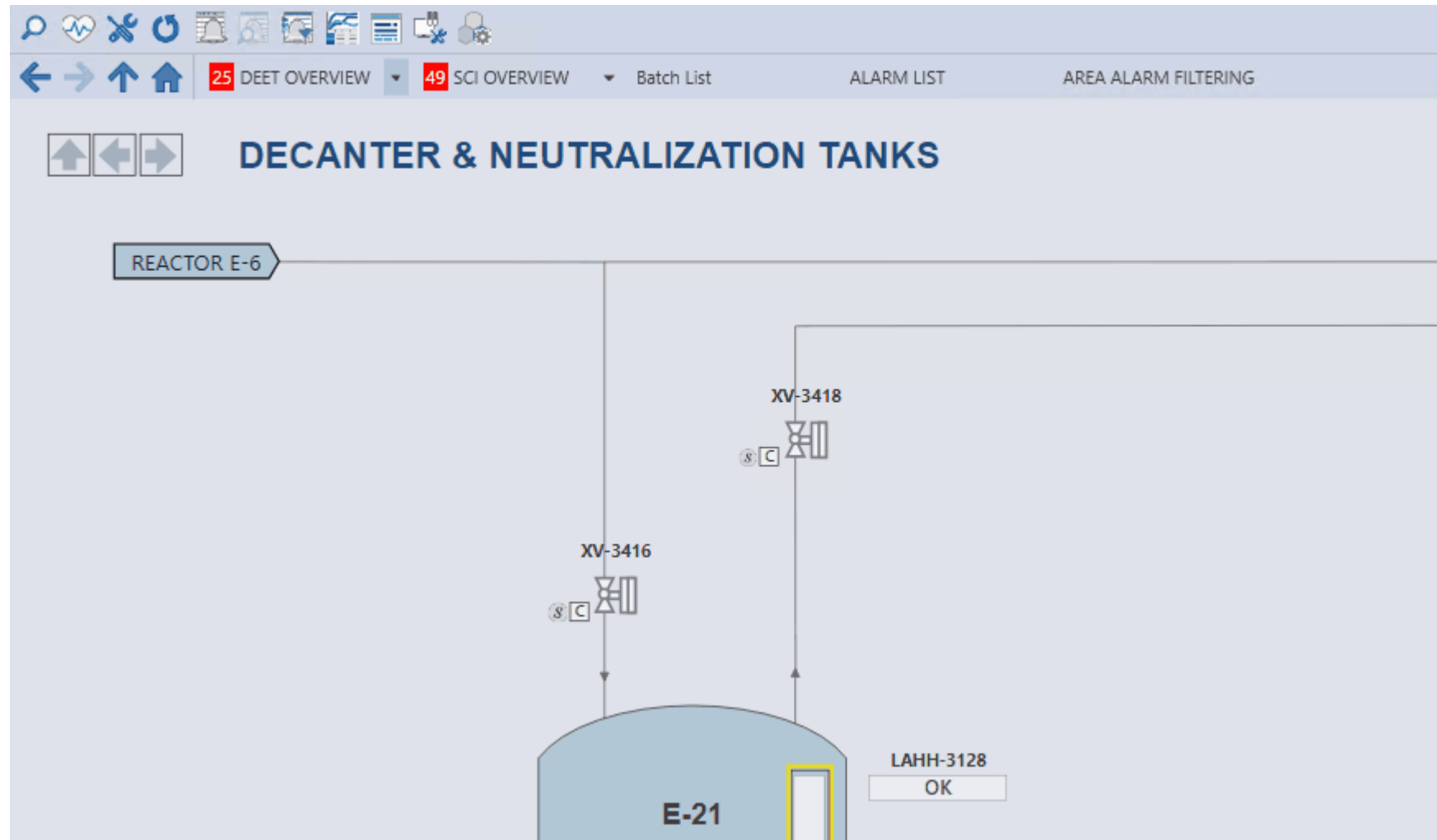

High-Performance Graphics

State of the System – Level 3 Displays

- Existing Level 3 (L3) displays were created similar to P&IDs leading to many process line intersections:

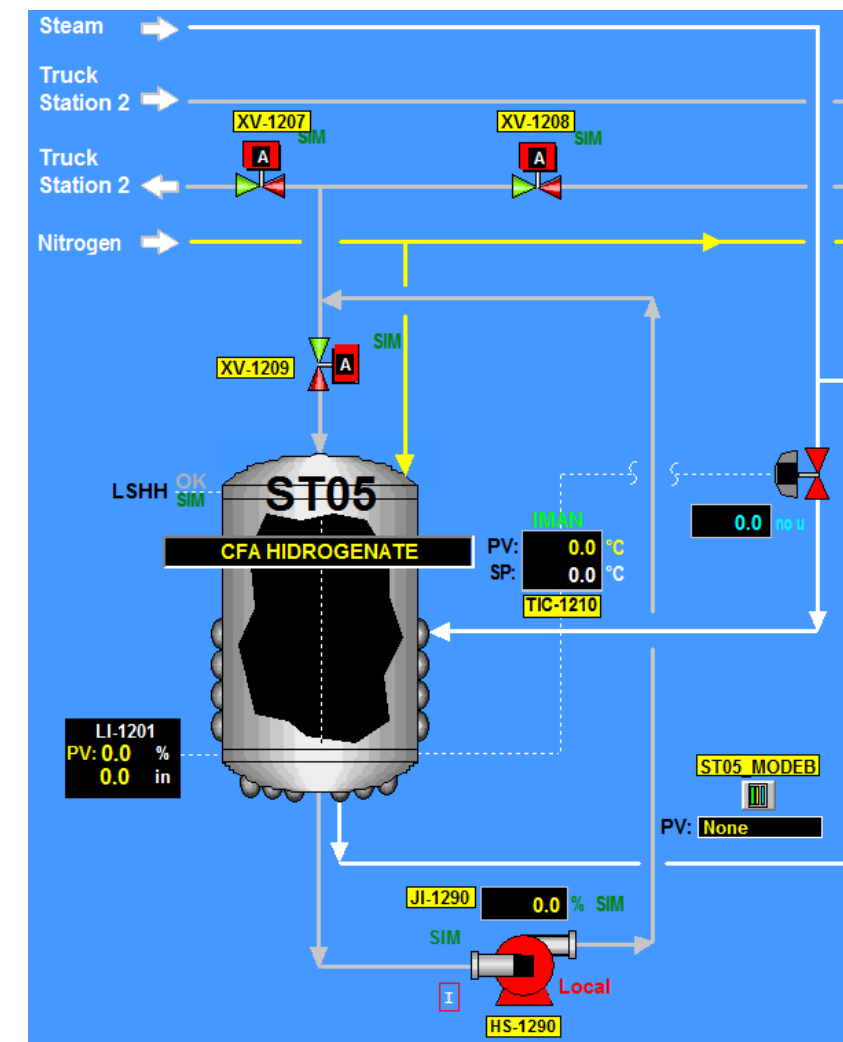
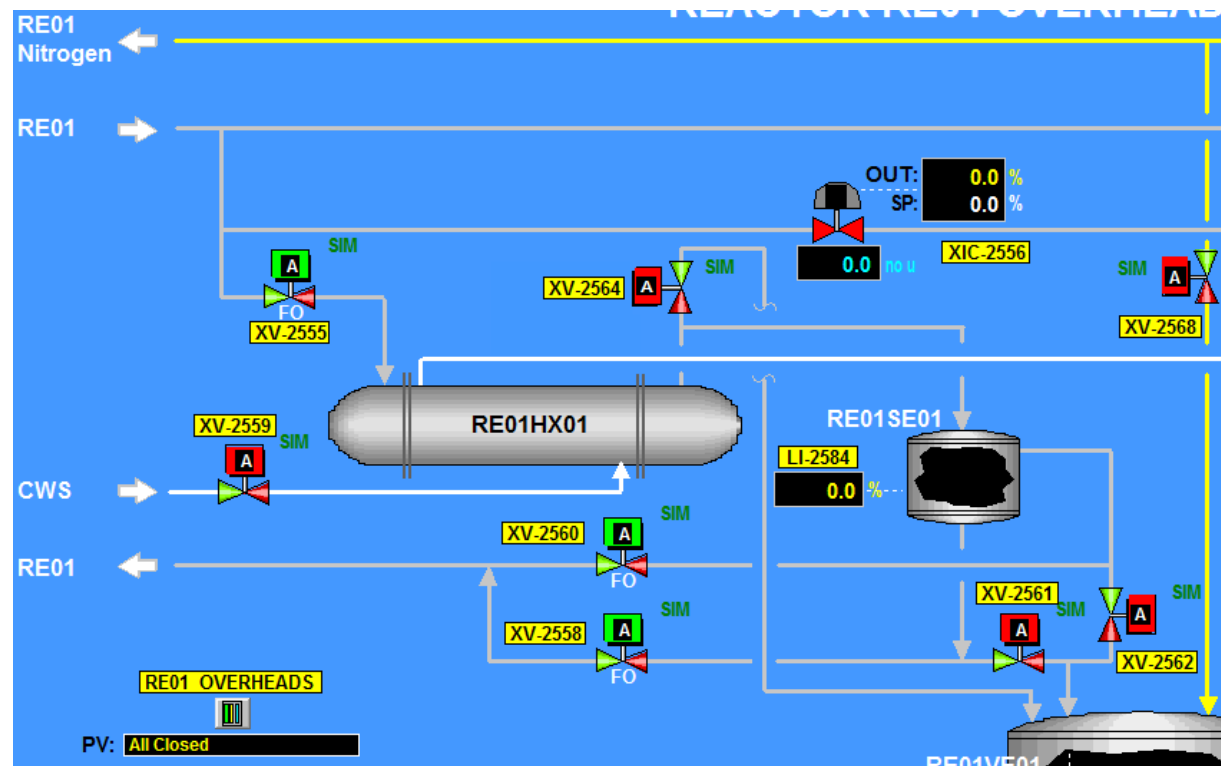

State of the System – Level 3 Displays

- Existing Level 3 (L3) displays were created similar to P&IDs leading to many process line intersections:

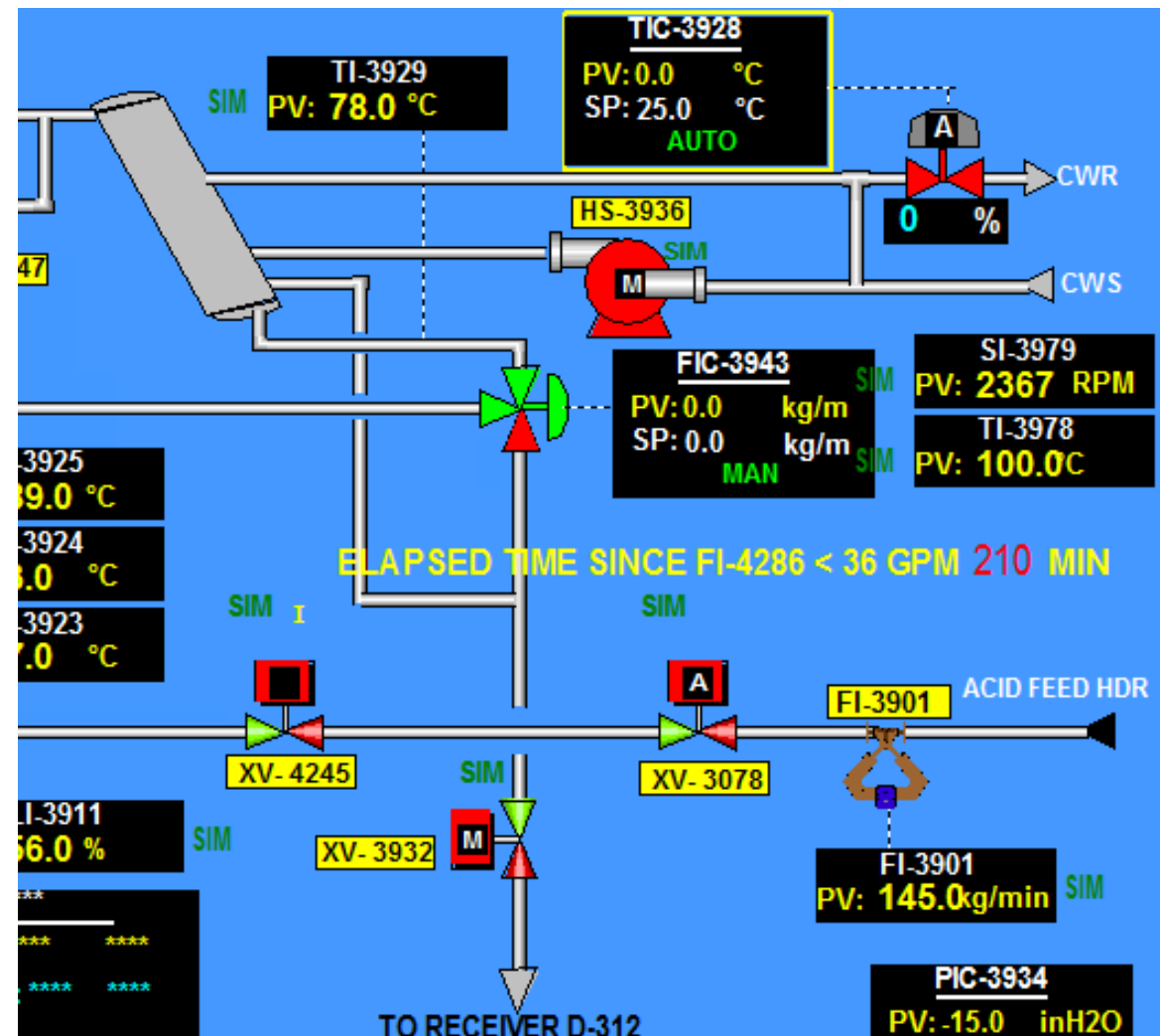

State of the System – Level 3 Displays

- Displays were cluttered with detailed information that wasn't necessary for day-to-day operation:

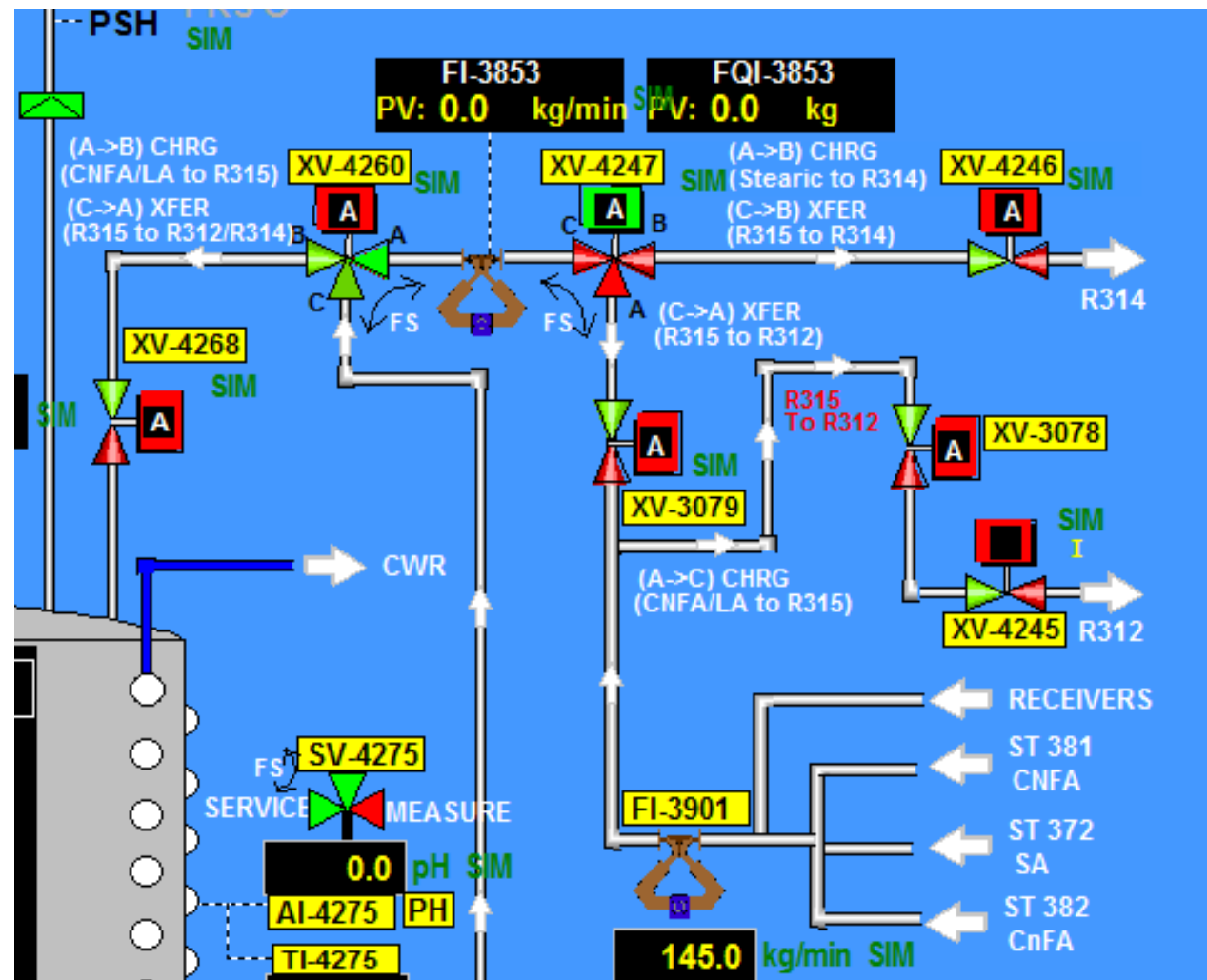

State of the System – Level 3 Displays

- Large amounts of data for the operator to process, adding to cognitive load:

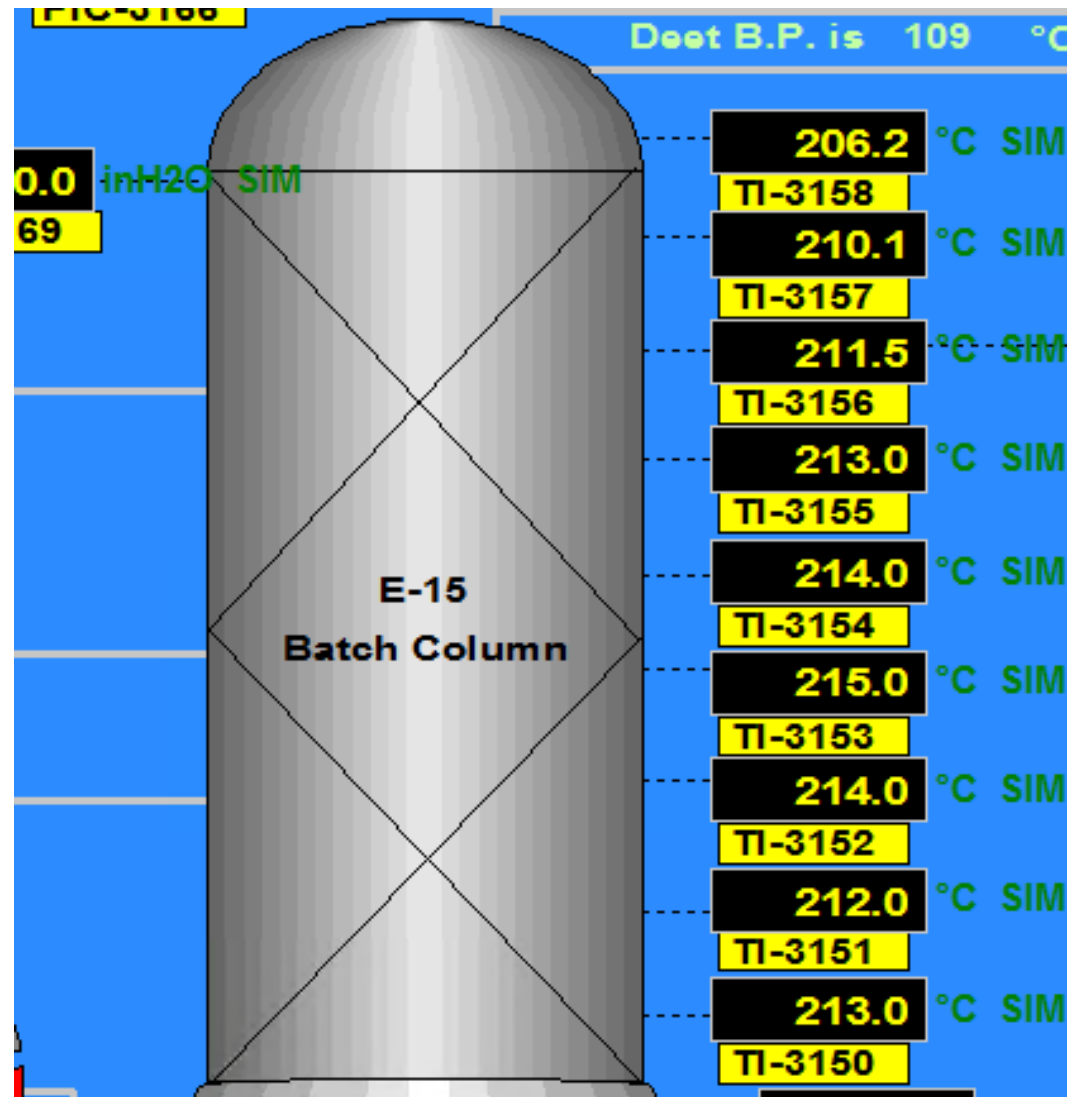

Simplifying L3 Displays

- Process lines were cleaned up to enhance interpretability:

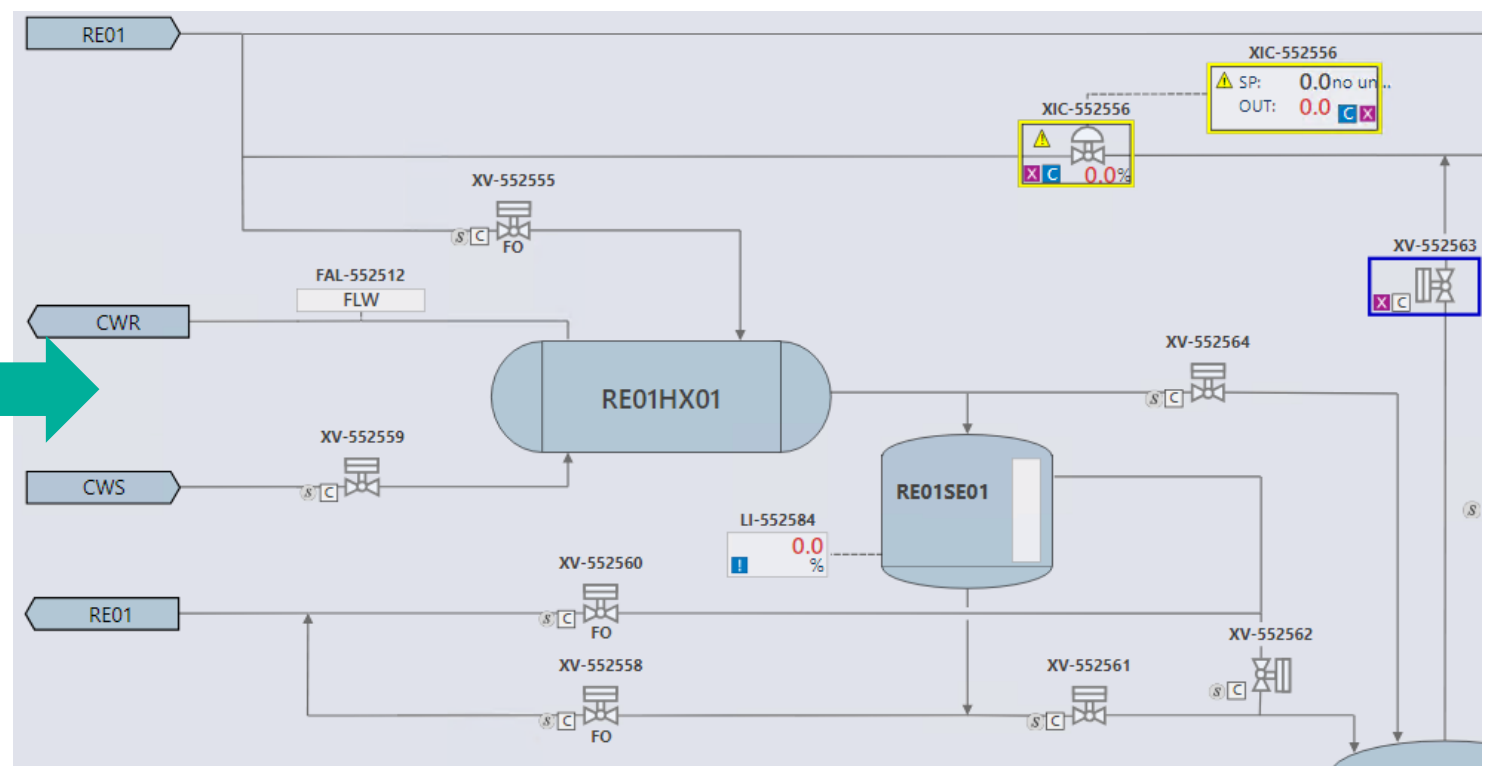
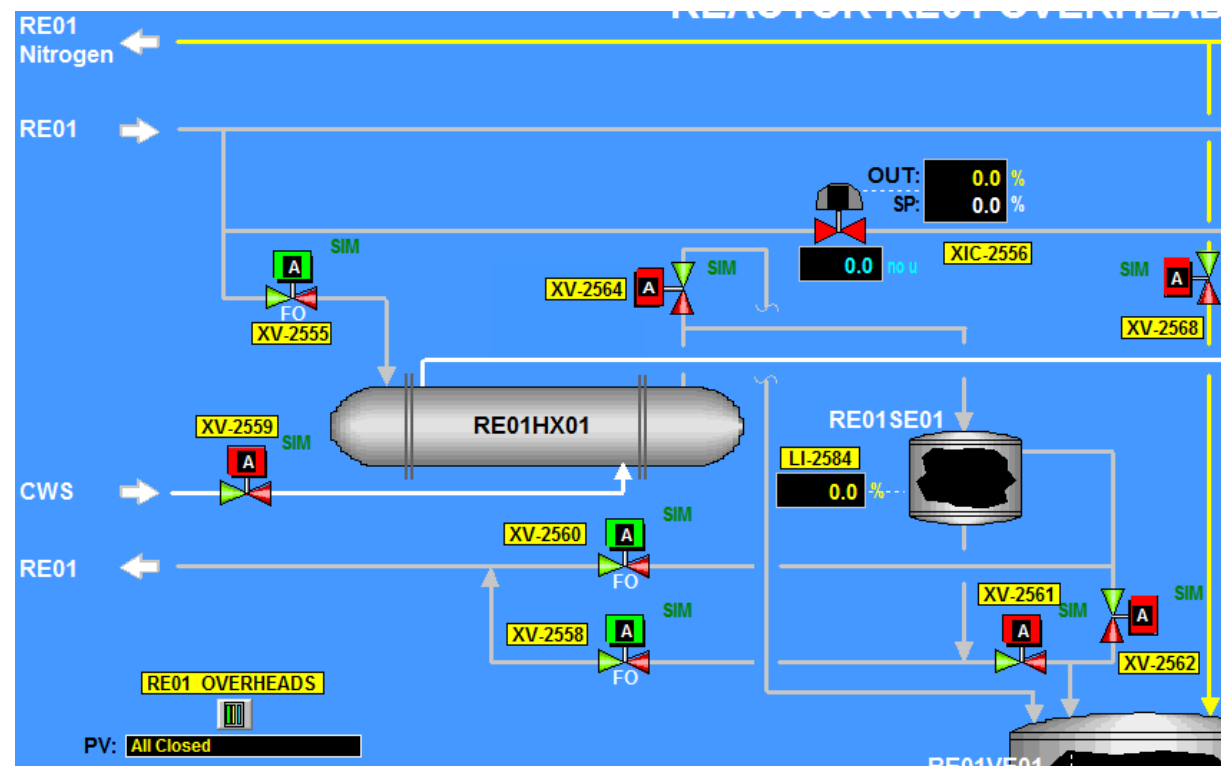

Simplifying L3 Displays

- Process lines were cleaned up to enhance interpretability:

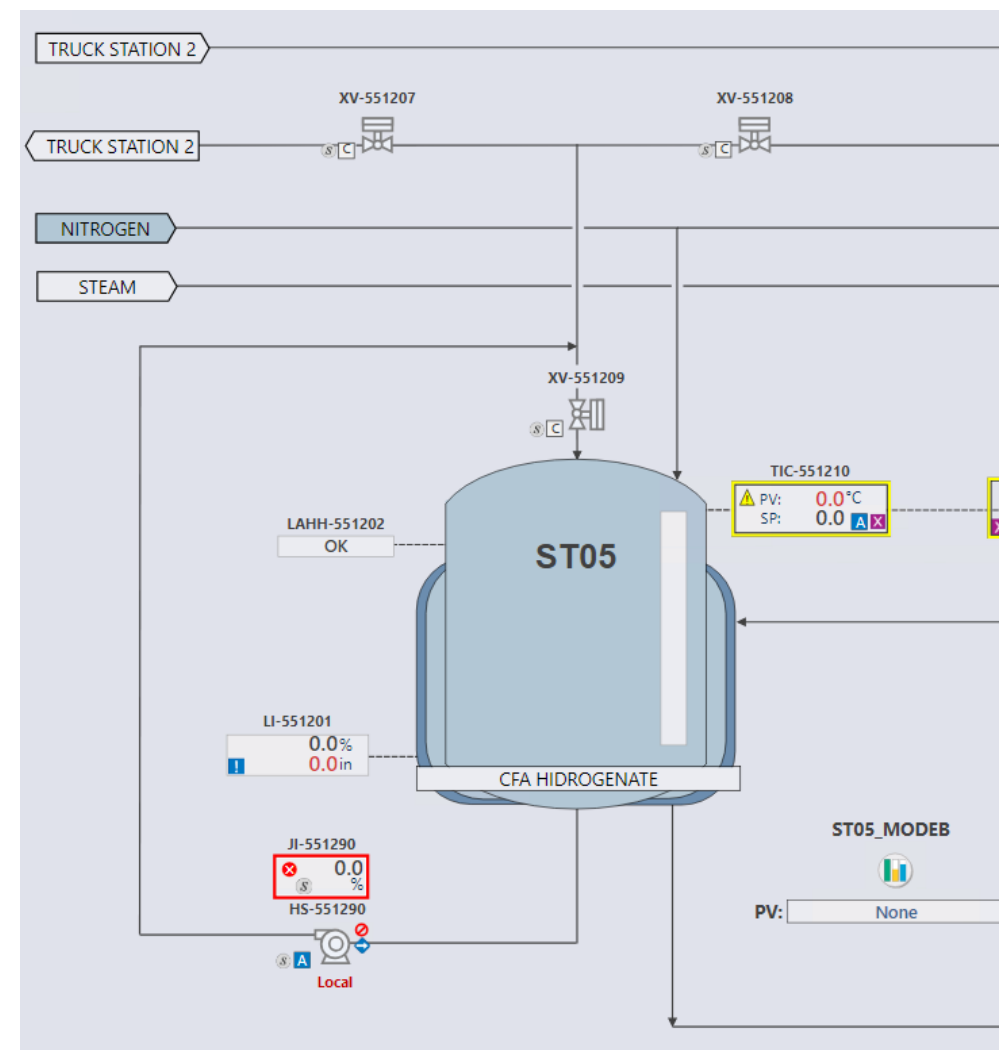
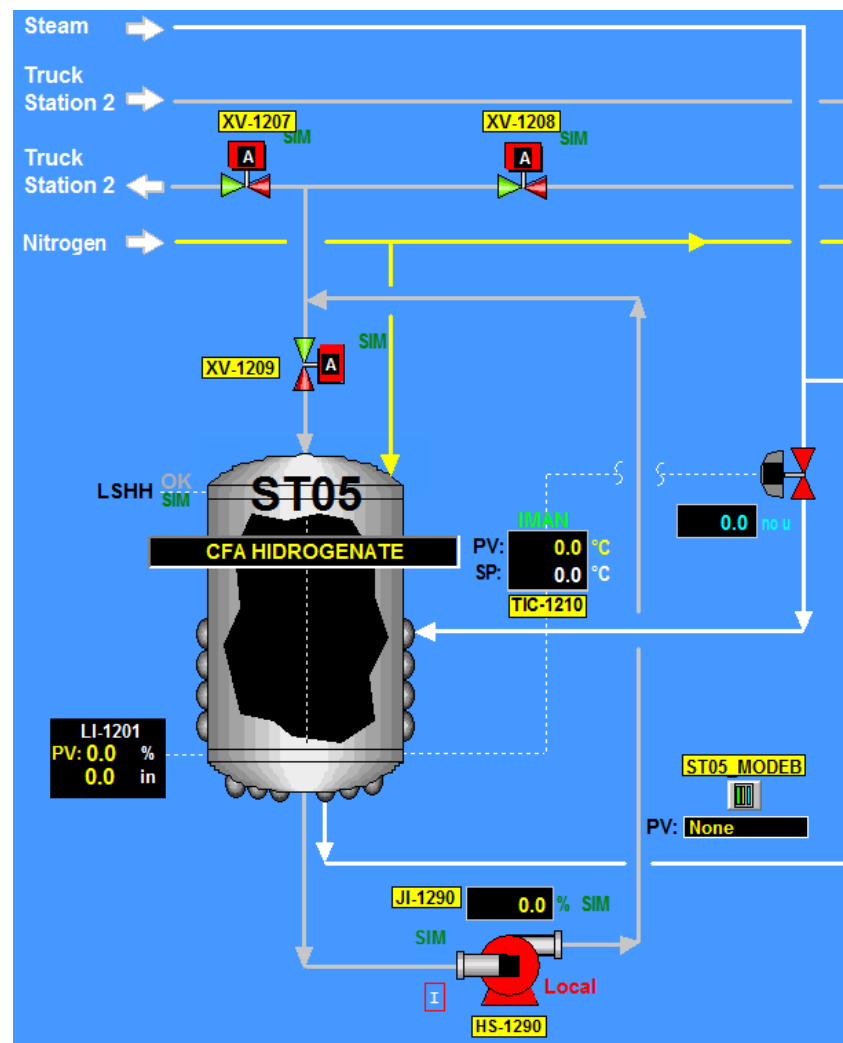

Simplifying L3 Displays

- Process lines were cleaned up to enhance interpretability:

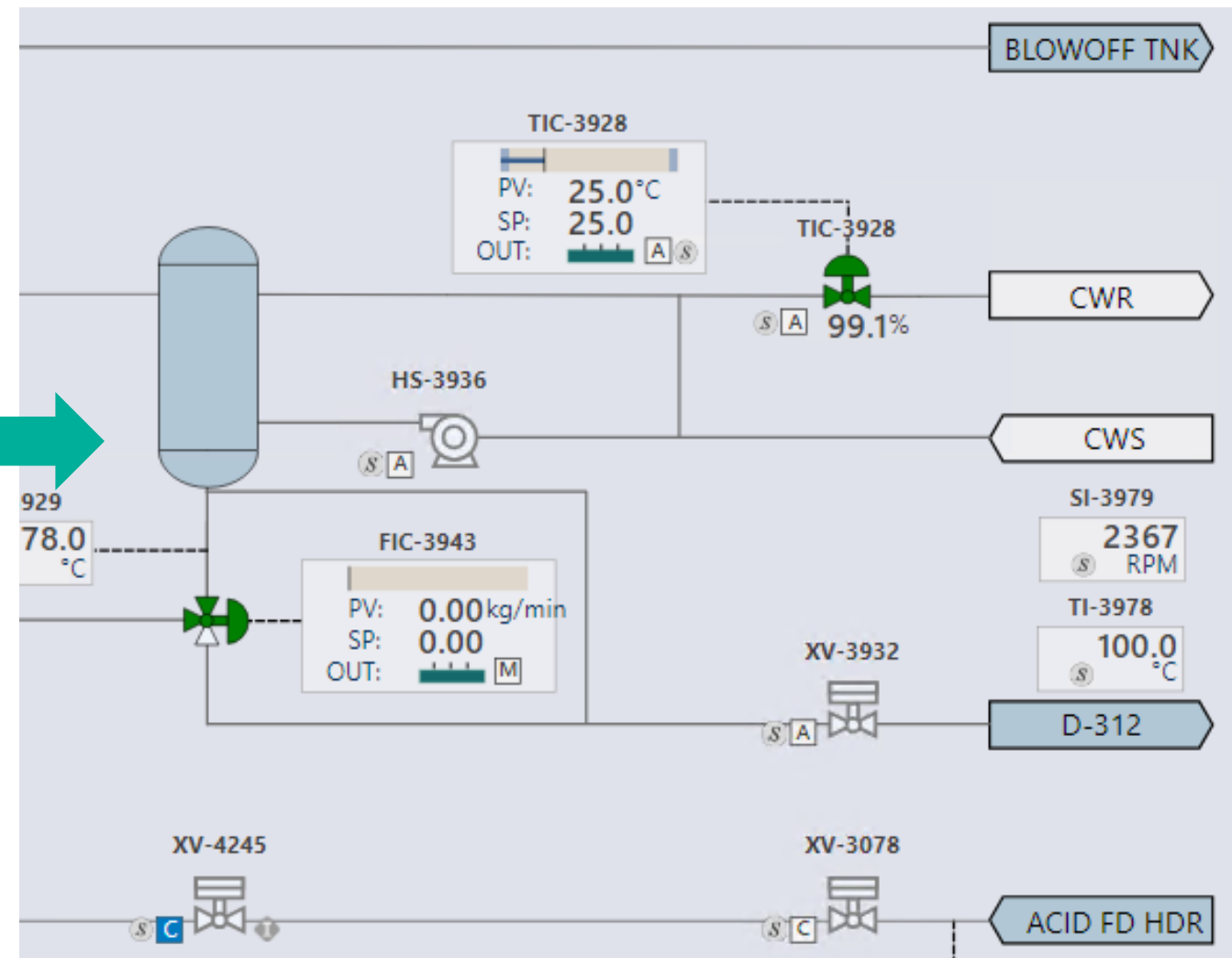
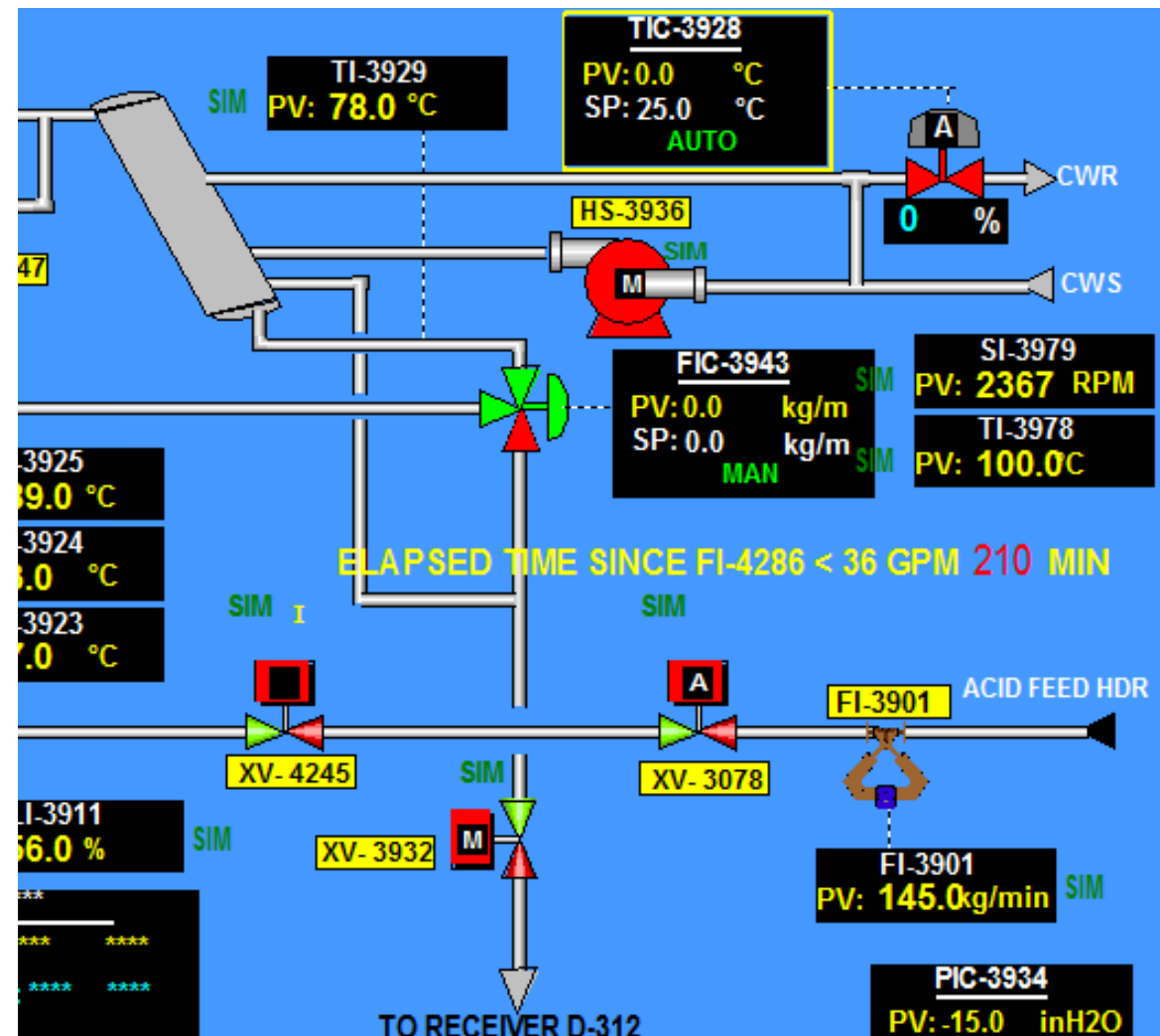

Simplifying L3 Displays

- Detail information was removed and provided in a popup available to operators:

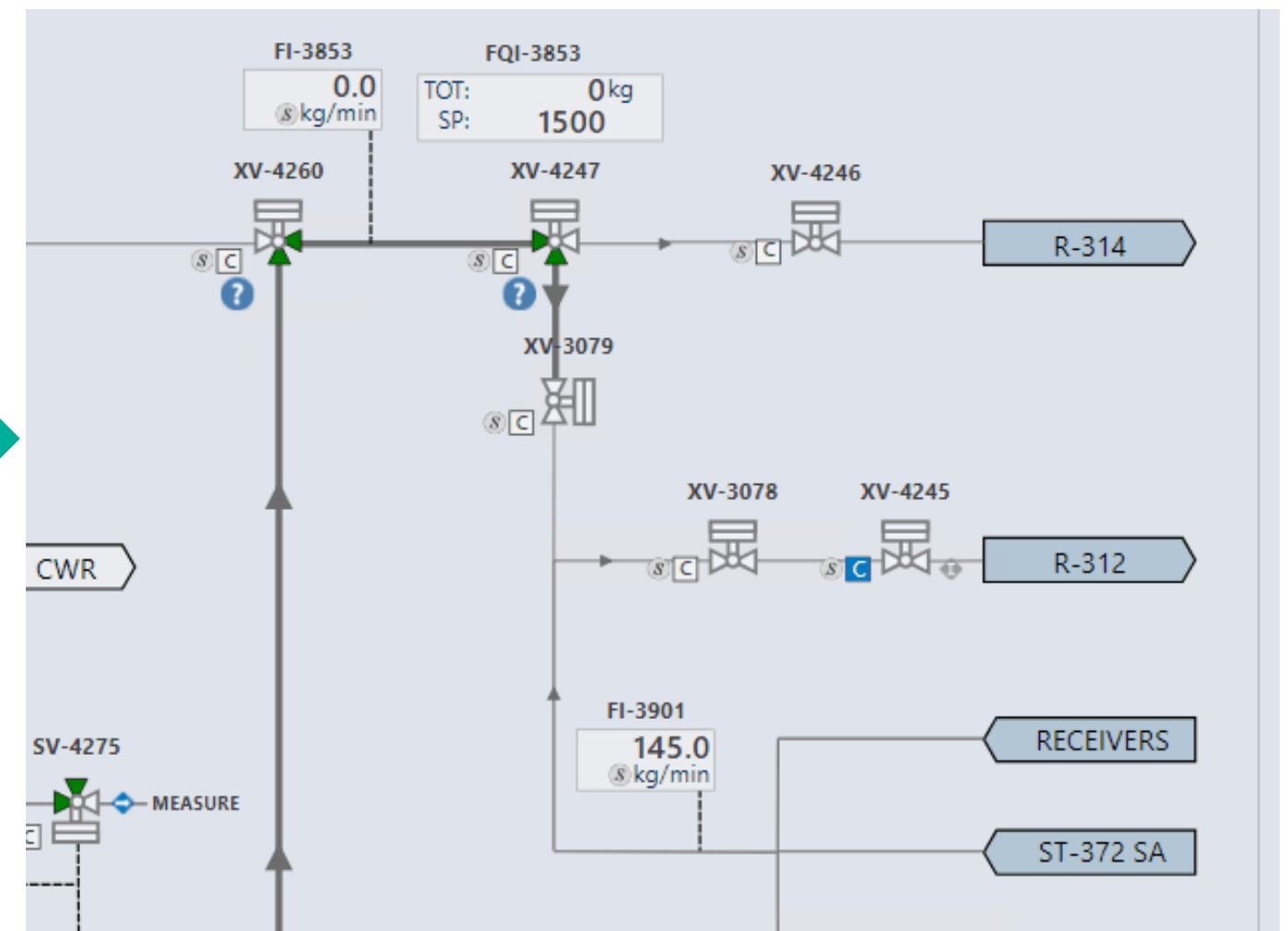
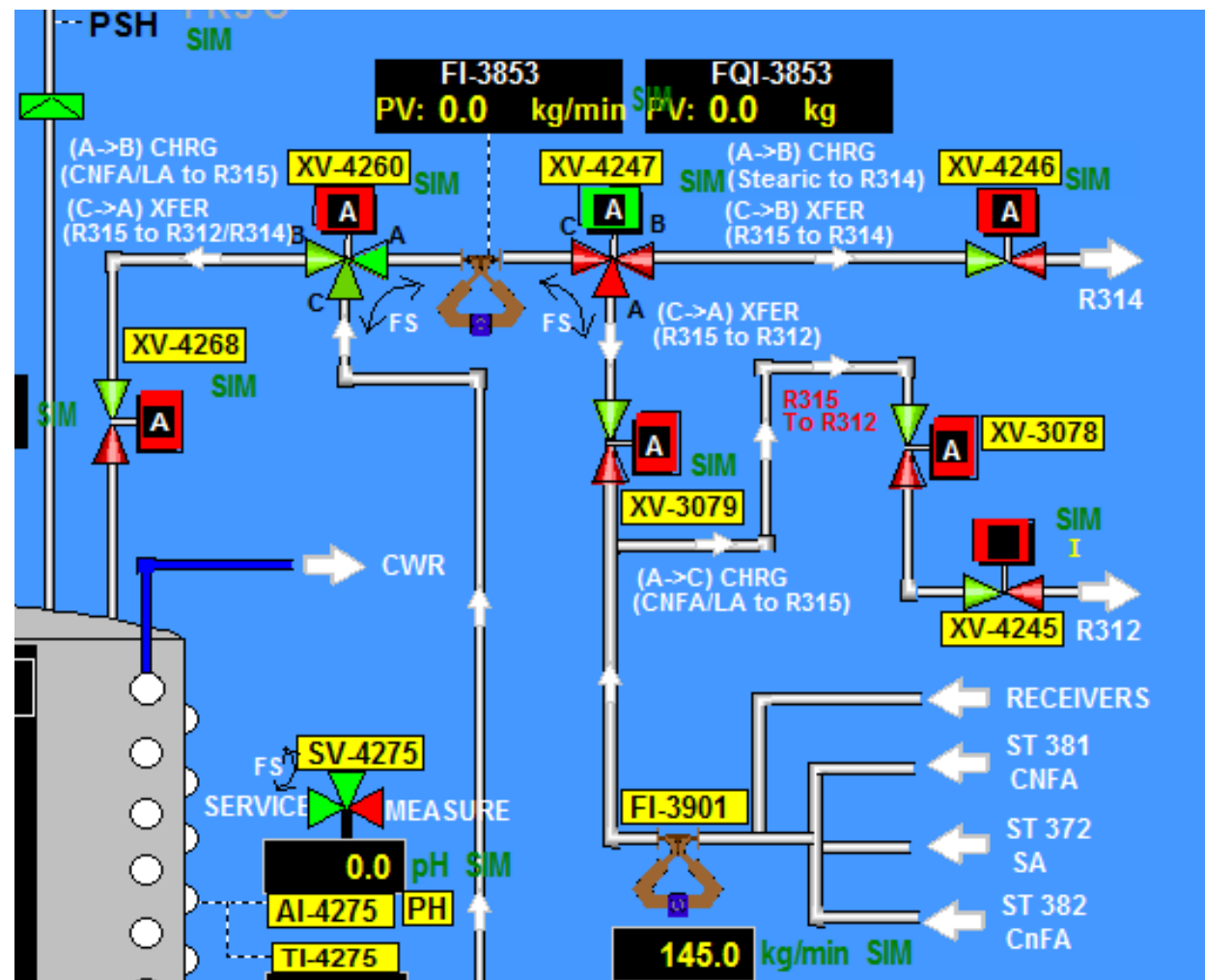

Temperature Profile

- Existing Level 3 (L3) displays were created similar to P&IDs leading to many process line intersections:

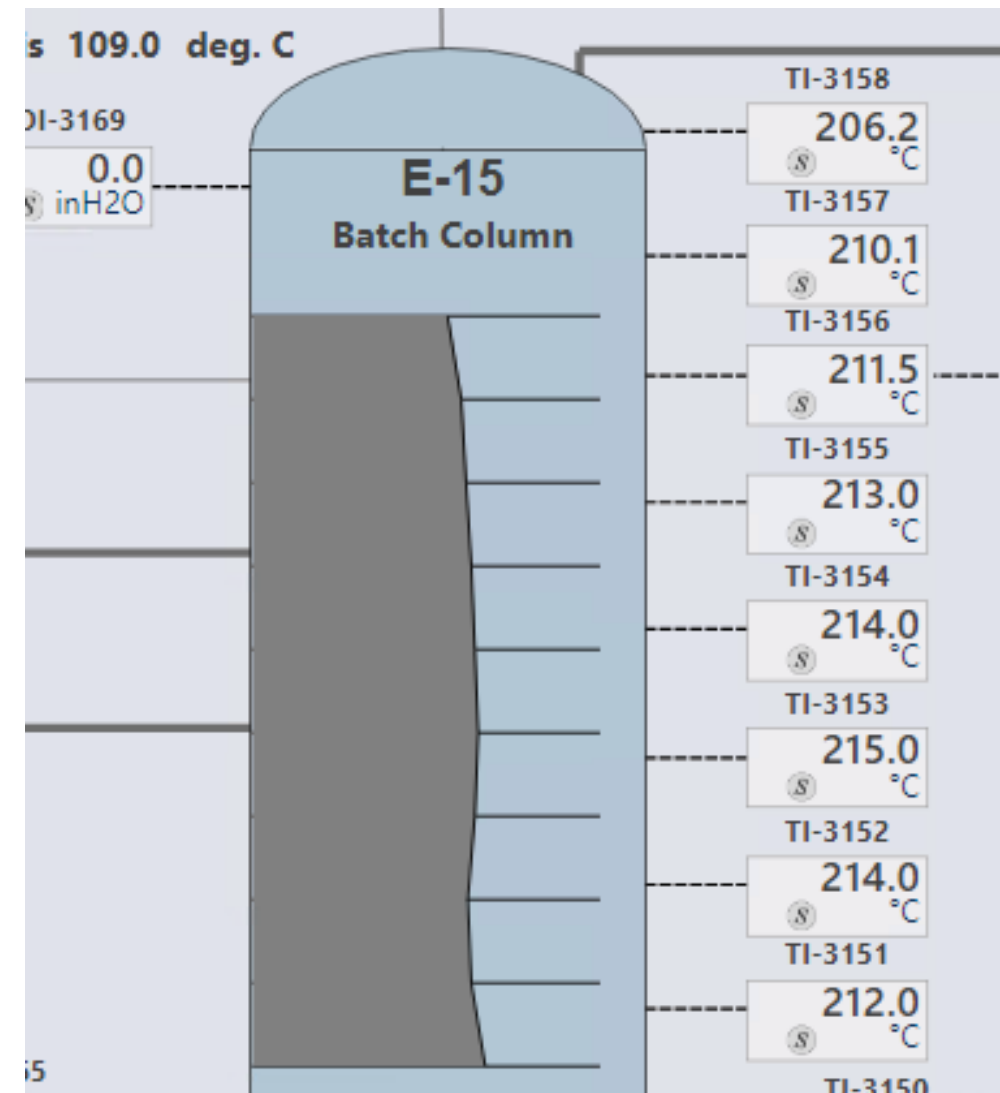
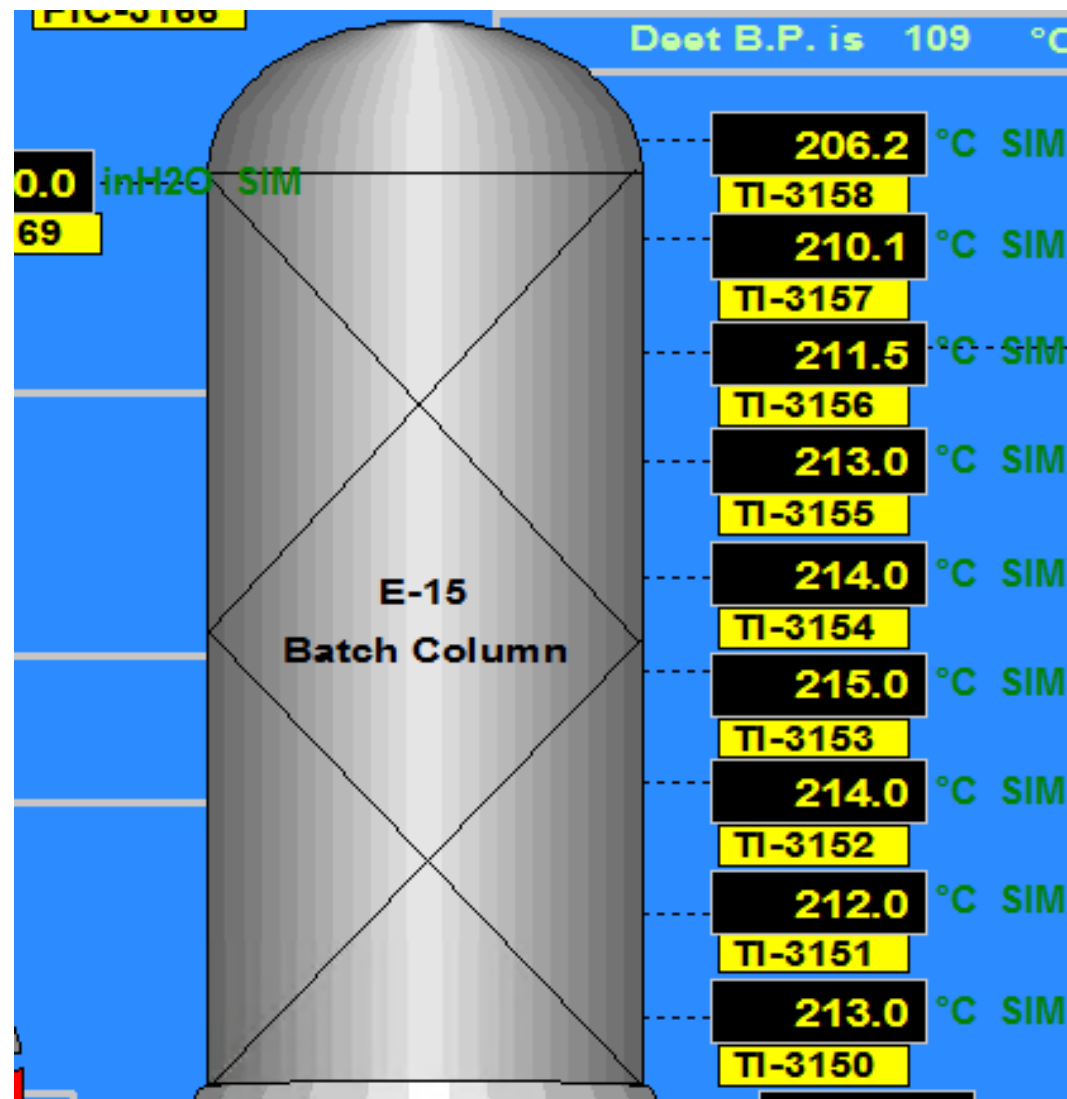



EMERSON EXCHANGE 2025

ACCELERATING
INNOVATION

Thank You