



ACCELERATING INNOVATION



ACCELERATING
INNOVATION

**Modernize Your Protection
System with Easy Swap-Out and
Integration to DeltaV™**

Disclaimer

The information and/or opinions expressed in this presentation are those of the authors and do not necessarily represent official policy or permission of Emerson or Emerson Exchange.

Important Reminders

Photography and audio/video recording is not permitted in any session, or in the exhibition areas, without press credentials or written permission from Emerson or Emerson Exchange.

Inquiries should be directed to:
EmersonExchange@Emerson.com



Salim Jaffer

Reliability Solutions Business Development Manager / Puffer - Sweiven



Björn Müller

Product Manager Online Systems & Sensors / Emerson



We are Your One Team Emerson

Emerson Impact Partner



Emerson Impact Partner



Global Leadership

- Technology Innovation & Scale
- Breadth of Portfolio in Product, Technology and Solutions
- Proven Performance Methodologies:
 - Operational Certainty
 - Project Certainty
- Global Best Value Manufacturing



Local Leadership

- Availability, Accessibility & Support
- Differentiated Customer Service
- Lifecycle Expertise & Infrastructure
- Close to Customer, Agile & Flexible
- Consistency in Applied Solutions
- Employee Owned and Vested

Combining Emerson's Proven Technologies and Processes with Local Expertise and Support to
Deliver Consistent, Reliable and Predictable Customer Outcomes

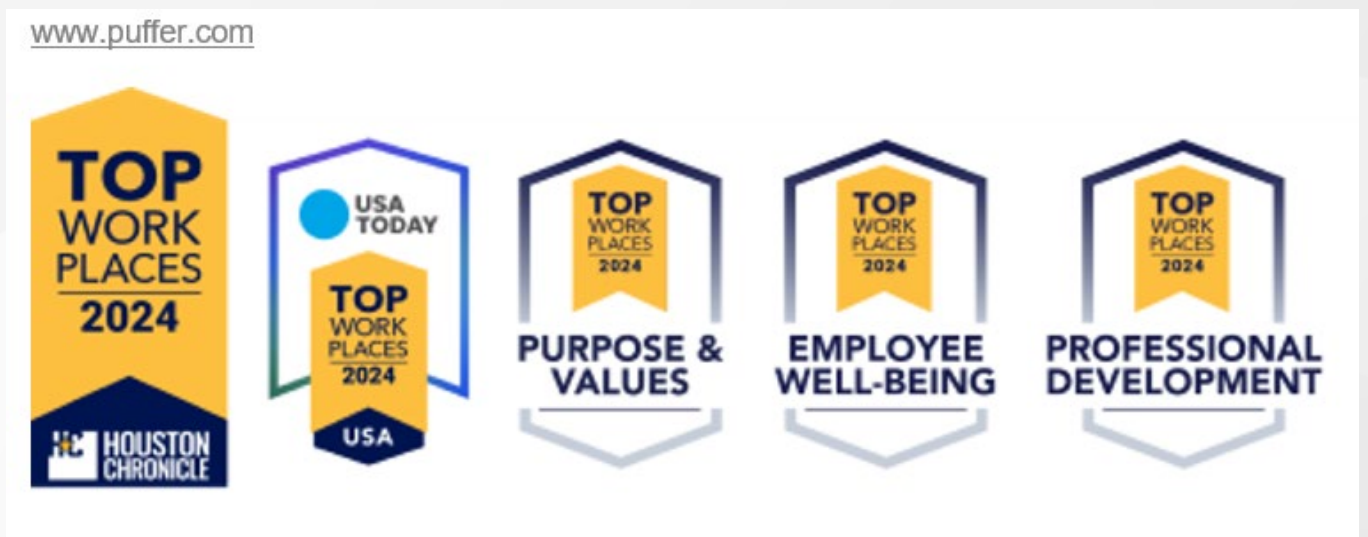

Puffer Sweiven

Since 1945, Puffer-Sweiven has set and improved the standard in equipment and services for process control, automation, safety, and reliability. Our tenured staff of industry experts consistently collaborates and delivers solutions to complex challenges and enables process-intensive facilities to run more efficiently and safely.

As an Emerson Impact Partner, Puffer-Sweiven serves as a local, single point of contact for sales, service and applied engineering for Emerson Automation Solutions in the Texas Gulf Coast and Central Texas area.

As part of an integrated, Emerson-certified network, we can combine our local capabilities with those of other members in North America to share resources and expertise that leverage Emerson's global reach and technologies. We can help customers achieve Top Quartile performance aligned with Emerson's Operational Certainty and Project Certainty methodologies.

Agenda

Björn Müller

Importance of Modernizing Online Systems

Björn Müller

Product Overview

Björn Müller

Applications & References

Salim Jaffer

Modernization of Protection Systems - Examples

Salim Jaffer

Supporting Collateral

Björn Müller

Easy Integration into DeltaV

All

Q & A

Importance of Modernizing Online Systems

Björn Müller

***Majority of the industrial installation use 30+ years old machinery protection systems.
Its time to modernize it using Emerson's AMS 6500 ATG with simply swapping out,
mostly using the same sensors, you currently have installed.***

Why Online Protection & Prediction?

- Online systems continuously monitor the Asset to protect and predict against damage, to ensure production reliability, to reduce non-operation periods/costs and to prohibit risks for humans, machines and the environment.

Shutdown critical assets when vibration reaches a certain level to ...

- Prevent catastrophic machine damage
- Protect human safety
- Avoid environmental releases
- Meet insurance requirements

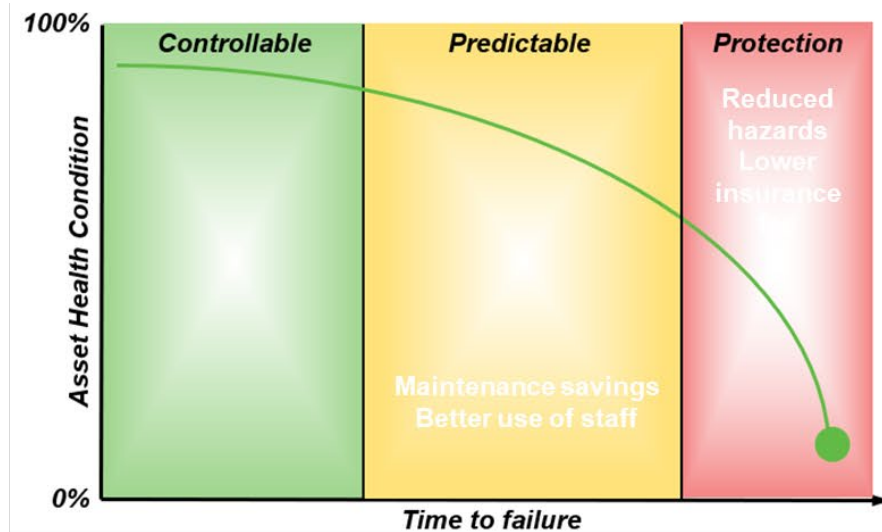

Plan and schedule maintenance and make early decisions to ...

- Improve plant uptime
- Plan labor and parts
- Prioritize maintenance activities
- Extend mean time between repair
- Aide process control decisions based on real asset status



We don't want this happening to customers

Why Modernizing existing Online Systems?

- There is lot of „OLD“ and/or „OBSOLETE“ Online Protection Systems out there:
 - Providing no or not sufficient support
 - High cost and long lead times for spare parts, if even available.



AMS 6500 ATG est. 2016

- *State-of-the-Art Hardware*
- *Continuous developments*
- *API 670 compliant*
- *Embedded Predictive Diagnostics*
- *Easy Control System integration*

Obsolete

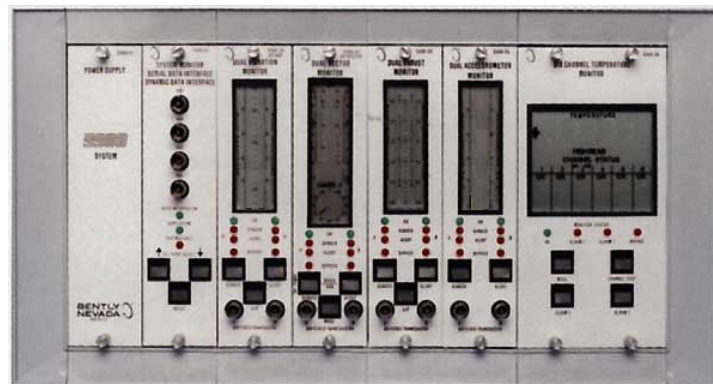

BN 3300
1988 – 2014

30 years old

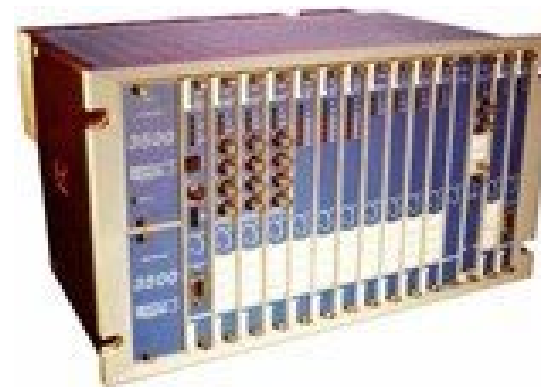

BN 3500
1995 –

Product Overview

Björn Müller

AMS 6500 ATG – System Hardware Overview

STANDARD RACK



22 Channel, 16 Relays, Redundant Interface

REDUNDANT RELAY

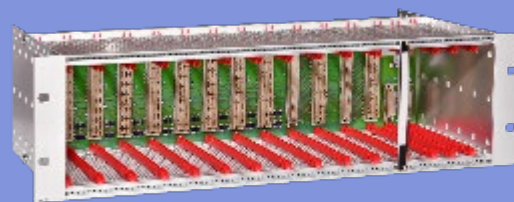

18 Channel, 32 Relays, Redundant Interface

WALL MOUNT

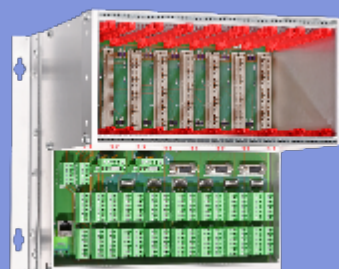

12 Channel
16 Relays
Single Interface

UNIVERSAL MEASUREMENT A6500-UM



- Relative and absolute Vibration
- Hydro (Low Frequency) Vibration
- Position / Thrust / Expansion
- Key / Speed



- Eddy Current



- Accelerometer



- MPU Tacho



- Seismic Velocity



- LVDTs



- Hall Effect



- Dynamic Pressure

State of the Art HW
Easy to use

Reduce Spare Parts and Cost

TEMP & PROCESS A6500-TP

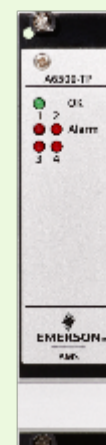

- 4 Process Inputs (Voltage or Current)
- Up to 8 RTD or Thermocouple Temperature Inputs

RELAY & LOGIC A6500-RC

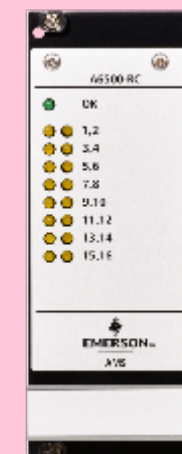

- 16 Changeover Relay Outputs
- Programmable Logic

COMMUNICATION CARD A6500-CC



- 1 Ethernet Port
- 1 USB Configuration Port
- Modbus RTU & TCP/IP Data Interface
- Embedded OPC UA (Server)
- TCP Configuration
- Mobile App (ATG View)
- AMS Machine Works Interface

COMMUNICATION CARD PRO A6500-CP



- 2 Ethernet Ports
- 1 USB Configuration Port
- Physical Key Lock
- User Management
- Cyber Security Certificate
- Embedded Webserver for configurable LiveView Dashboards
- TCP Configuration, Modbus, OPC-UA, Mobile APP & AMS Machine Works Interface

Embedded PeakVue™ Technology

- Single value anyone can interpret
- Earlier warning than any other technology
- Indication of fault and severity
- Emerson's patented PeakVue methodology is separating very high frequency, short duration stress waves from regular vibration data.
- Early detection of Rolling Element bearing failures.
- AMS 6500 ATG Universal Measurement cards include PeakVue technology.

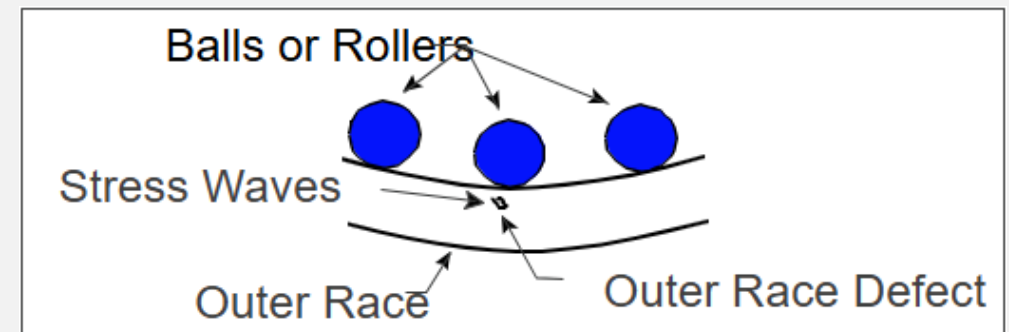
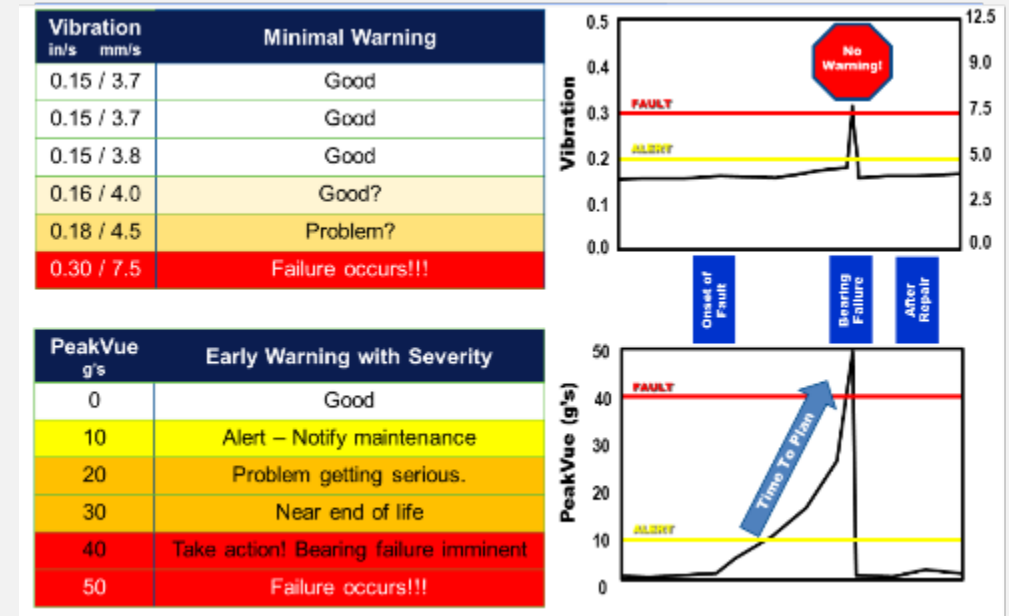

AMS EZ 1000

- Easy field calibration & Factory Calibration Option
- Fully API 670 compliant
- Compatible to 3rd party sensors
- Eliminates product complexity, just one part number for:
 - Emerson 5mm, 8mm 16mm & 32mm sensors
 - 3rd party sensors
 - Extended measuring range
- USB interface for configuration of Sensor, Cable Length, Target Material & Measuring Range
- Functional Safety enabled: SIL2 Capable



UNPARALLELED FLEXIBILITY

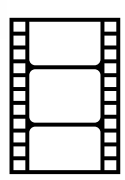

Making Eddy Current measurements easy:
[Making Eddy Current Measurement Easy with the AMS EZ 1000](#)



MAKING EDDY CURRENT MEASUREMENT EASY



Industry Statistics – Bearing Failure causes

LUBRICATION RELATED 65%

- Lubrication Contamination 48%
- Corrosion 4% (due to water in the oil)
- Improper Lubrication 13%

INSTALLATION or MECHANICAL RELATED 32%

- Loading 4% (poor design or related to poor clearances setup)
- Misalignment 13% (poor installation)
- Assembly 15% (poor assembly/clearances leads to stresses)

Others 3%

BEARING FAILURE MODES

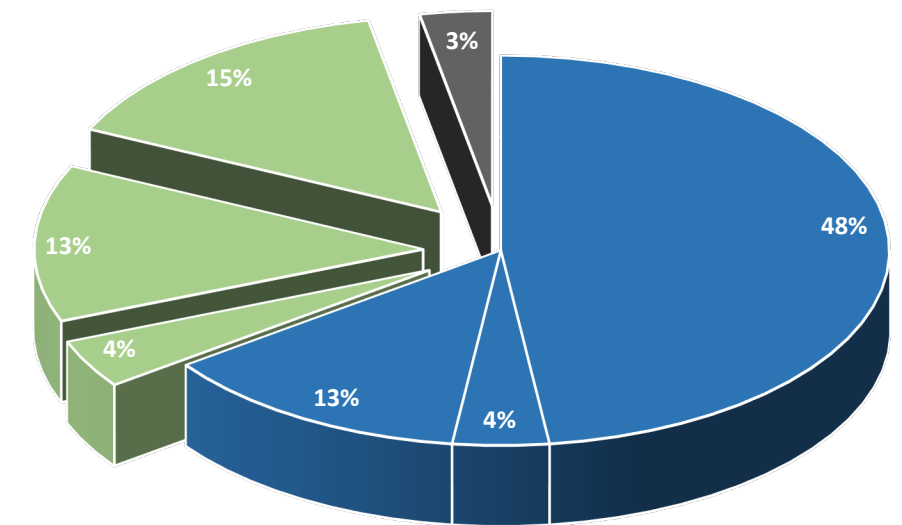

Applications & References

Björn Müller

Online System Applications

- Relevant and State-of-the-Art measurement applications per API 670

Power & Oil / Gas

LNG

Refining

Chemical

Pulp & Paper

Mining

Calculation based on two channels

Channel 1 & 2

Absolute bearing vibration
 Absolute bearing vibration (low frequency)
 Absolute shaft vibration
 Cylinder pressure
 Relative shaft vibration
 Relative shaft vibration (low frequency)
 Speed
 Speed (redundant)
 Tandem/Cone

Available evaluations:

Acceleration Smax, Acceleration Smax P-P, Velocity Smax, Velocity Smax P-P, Displacement Smax, Displacement Smax P-P, Voltage input Smax, Voltage input Smax P-P

Two separate channels

Channel 1

Absolute bearing vibration
 Absolute bearing vibration (low frequency)
 Cylinder pressure
 Distance static
 Dynamic pressure
 Eccentricity
 Relative shaft vibration
 Relative shaft vibration (low frequency)
 Vibration (low frequency) with order analysis
 Disabled

Available evaluations:

Acceleration 0-P, Acceleration P-P, Acceleration RMS, Velocity 0-P, Velocity P-P, Velocity RMS, Displacement 0-P, Displacement P-P, Displacement RMS, Voltage input 0-P, Voltage input P-P, Voltage input RMS



Large Pumps



Aero derivative Turbines

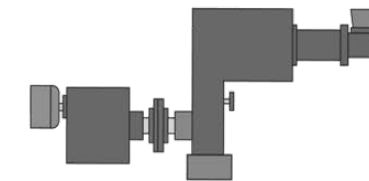

Extruders
(Motor & Gearbox)



Centrifugal Compressors



Steam Turbines



Generators



Gas Turbines



Large Motors



ID & FD Fans

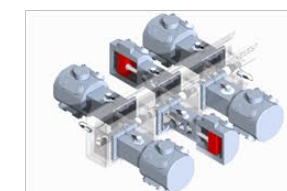

Recip Compressors

Emerson Online Protection References

End Users



Machine OEMs



Modernization of Protection/Prediction Systems - Examples

Salim Jaffer

Westinghouse 501 Steam Turbine in a petrochemical plant:

Customer Challenge

- World's second largest producer of petroleum-based needle coke had unsupported CSI 6500 Protection Systems.
- The Westinghouse Steam Turbine had three racks with Emerson™ sensors
- The goal was to upgrade to AMS 6500 ATG without effecting any existing functionality and add lube oil pump on-off status via A6500-RC Relay Card

Solution

- Puffer Reliability Solutions (RS) team took this project on:
 - First step was to conduct a site walk, take a full account of how each sensor was connected to the old CSI 6500 Racks
 - Check for compatibility of each component moving it to AMS 6500 ATG. Execute full turnkey project responsibility under RACI

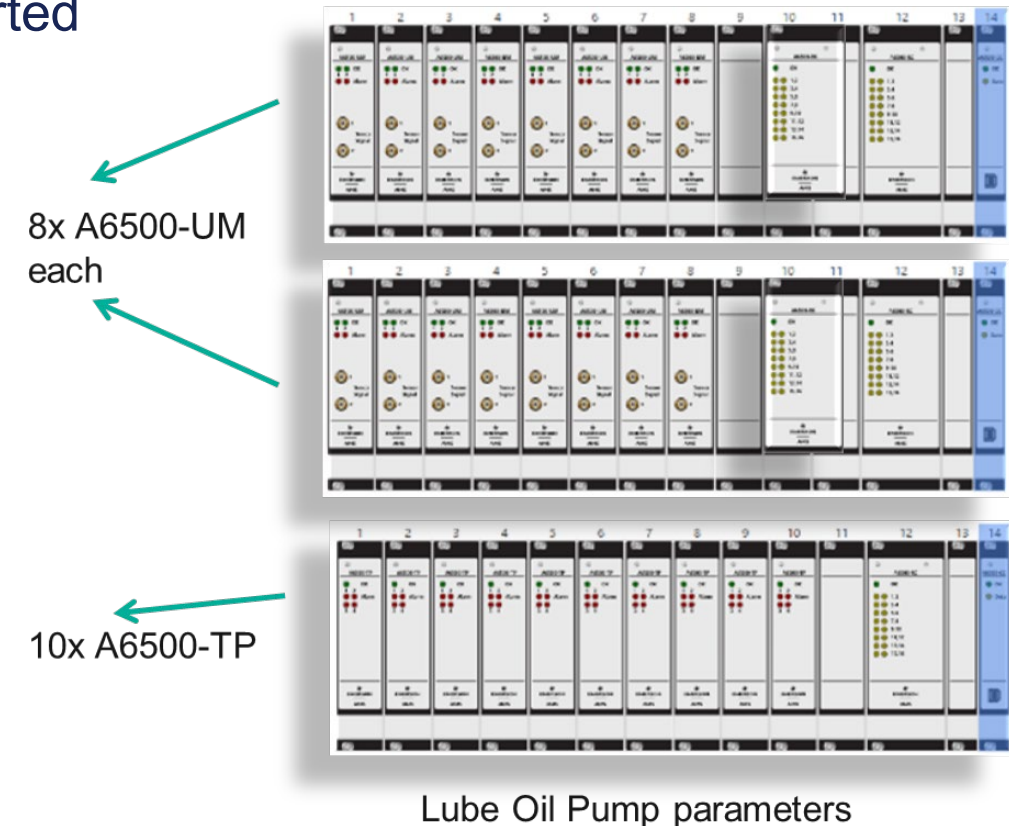

Result

- Initial Purchase Order received was for **\$184,346** covering hardware, software commissioning services using the existing cabinet connected to DeltaV
- Customer addressed unsupported hardware and added functionality and life of the system. In the following years, customer upgraded all sensors to EZ 1000 Series

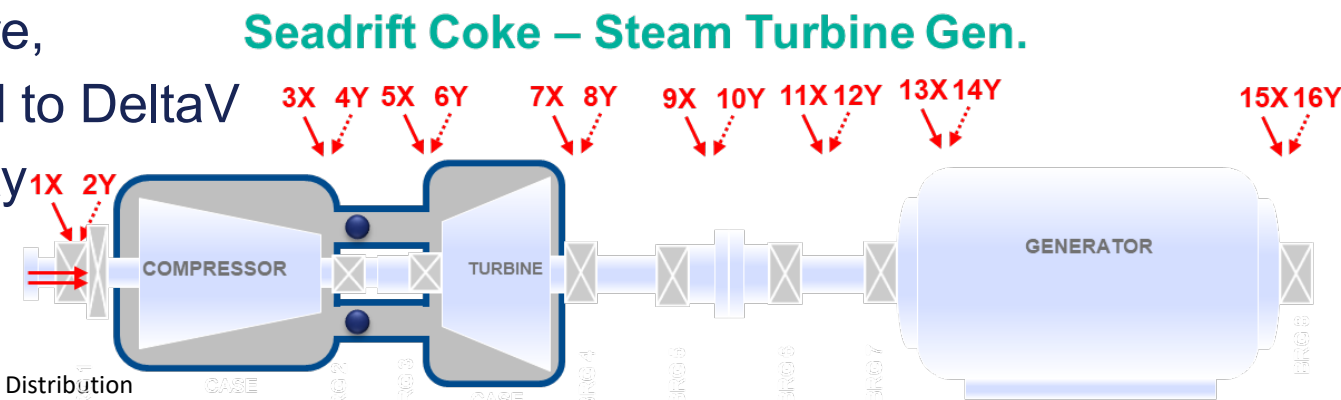

Three GE Frame 7A Gas Turbines

Customer Challenge

- BN 3300 Series system was obsolete and upgrade path to Orbit 60 was cost prohibitive.
- GE OSM (On-site Management) contract required to send vibration data to Atlanta, GA at the GE remote monitoring center.
- BN support was not responsive to assist this critical power generation facility.

Solution

- Puffer Reliability Solutions (RS) team produced a WIN-WIN solution.
 - First step was to incorporate and configure the BN Sensors to AMS 6500 ATG Systems
 - Using AMS 2600 Machinery Health Expert Puffer submitted Start-up data which was sufficient to continue customers OSM contract with GE.

Result

- Total amount of the project was **\$136,437** covering all three gas turbines
- hardware, software commissioning services using the existing cabinets.
- Customer was able to maintain the GE OSM Contract
- Customer signed a reliability services contract with Puffer and expanded the ²² scope with additional modification to the cabinets with HMIs



GE Frame 7A Gas Turbines, Shiro, TX

Meet the Emerson Team

Mike Ivceovich – Account Manager
Salim Jaffer - BDM Puffer
Aaron Brodsky – Puffer Services



Reliability



Production



Safety



Energy



Sustainability

Reactor Motor of a Reciprocating Compressor for a critical chemical process

Customer Challenge

- For two years in a row, this facility lost \$ 0.5 Million each due to motor bearing failure despite of having a BN 3500 measuring acceleration on this Reciprocating Compressor
- Losses included repairs, production and safety citation

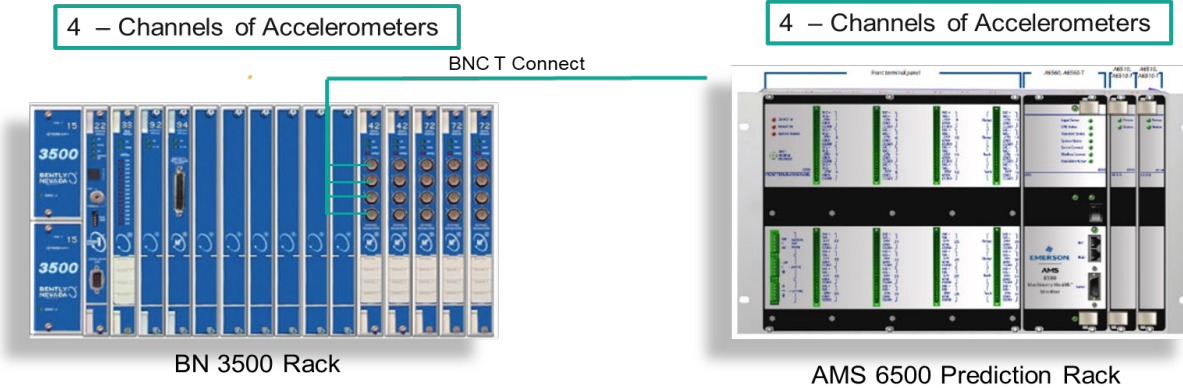

Solution

- An innovative solution was approached to capture the high energy impact forces from the 3 plus one additional accelerometers measuring PeakVue
 - BN 3500 Protection system was kept as is, but the rack buffered output were fed to Emerson AMS 6500 Prediction Rack measuring PeakVue
 - Customer also purchased condition monitoring software AMS Machinery Manager

Result

- Total amount of the project was **\$ 45,389** covering hardware, software commissioning services and modifying the existing cabinet. Also adding a server computer setting up a database & connect to DeltaV DCS.
- Customer signed a reliability services contract to ensure on-going support
- Peace of mind having added PeakVue measurements to protection & prediction.

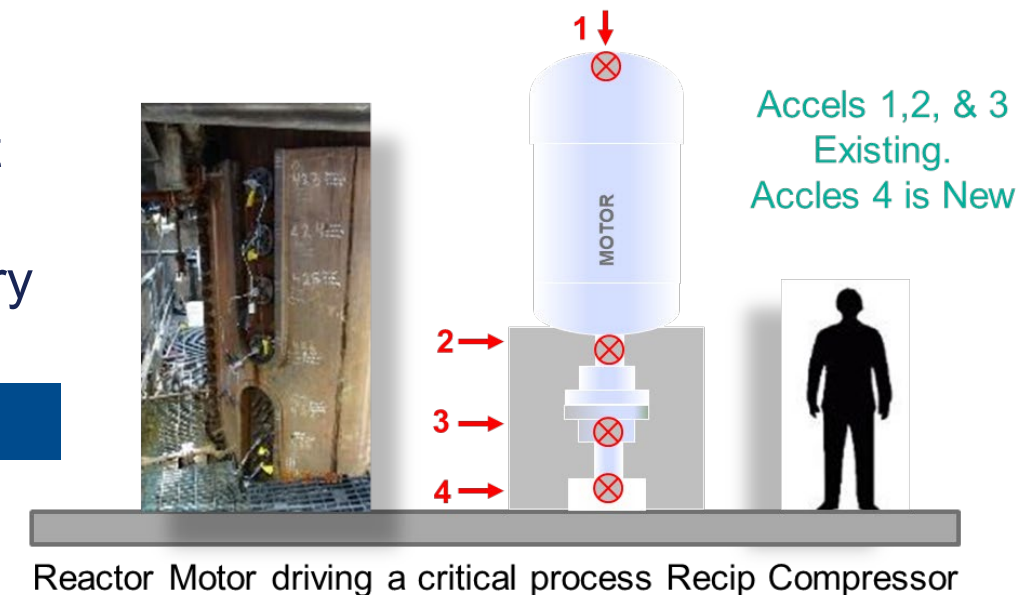

Three Oxygen, 2-Cylinder vertical Reciprocating Compressors by Burckhardt Switzerland in Channelview, TX on Air Separation Unit (ASU).

Customer Challenge

- Prior to this solution design, customer had vibration switches instead of going with expensive Reciprocating Compressors Monitoring Solutions by BN 3500, Prognost or Windrock.
- Customer had a failure in Asia which resulted in the loss of life, damaged property and goodwill of the company.

Solution

- For this new ASU O2 Compressors Puffer, was invited to design a solution with Emerson AMS 6500 ATG with sensors, & software.
- The design of 3 X AMS 6500 ATG with Emerson™ accelerometers, cables, Eddy current Phase probe, Junction boxes, AMS Machine Works licenses and Cabinets with FAT, SAT and full commissioning Services.

Result

- Total amount for the project: 3 X Mini racks **\$89,951** (special fleet pricing)
- Customer has standardized this solution fleetwide, it protects the compressors, capture vibration data and sends it to AI Models for analytics in PRiSM at the enterprise monitoring center. Connected to DeltaV DCS.

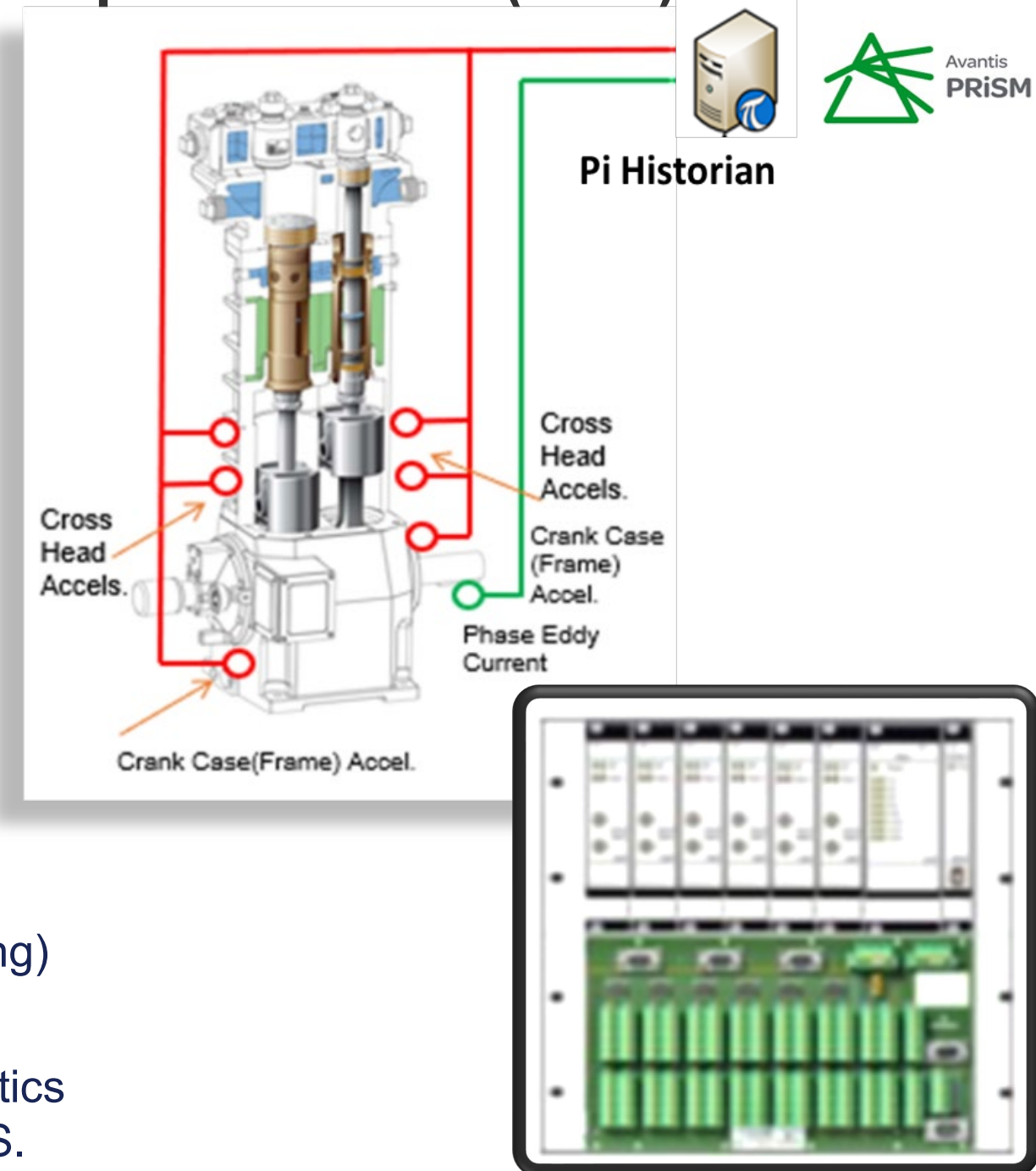

Two motor driven multistage Centrifugal Compressors at chemical plant for producing additive for lubricating oils in Deer Park.



Customer Challenge

- Two multistage centrifugal compressors K-83 & K-84 with minimal vibration points with no diagnostic data.
- These machines had failures and there was no way to conduct RCA with the minimal instrumentation and no prediction data.
- Hot-oil pump needed a system total 3 X AMS 6500 ATGs

Solution

- Puffer did a machine walkdown, recommended the following:
 - Included correct sensors on each bearing location and upgrade the rack with more cards and prediction license.
 - Customer also purchased condition monitoring software AMS Machine Works to conduct RCA looking at rich vibration data.

Result

- Total amount for the project: three racks with cabinets additional sensor and prediction license was **\$ 140,042** covering hardware, software commissioning services, modifying the existing cabinet & connected to DelatV DCS.
- State-of-the art vibration monitoring system communicating to the ²⁵DCS and protecting the machines

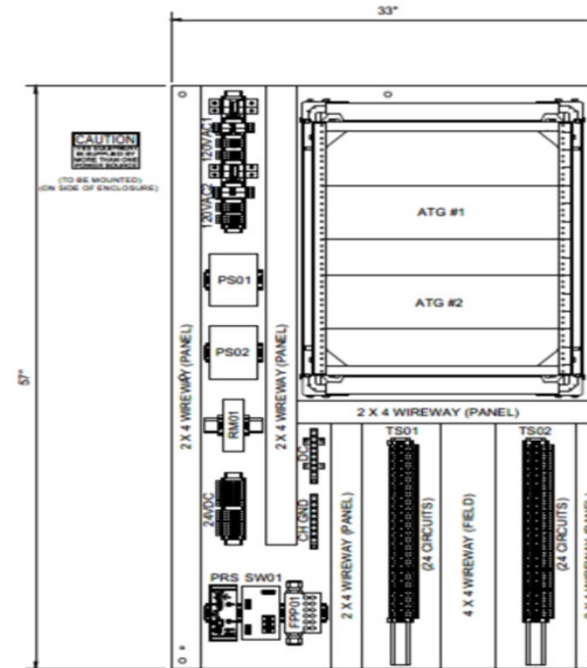
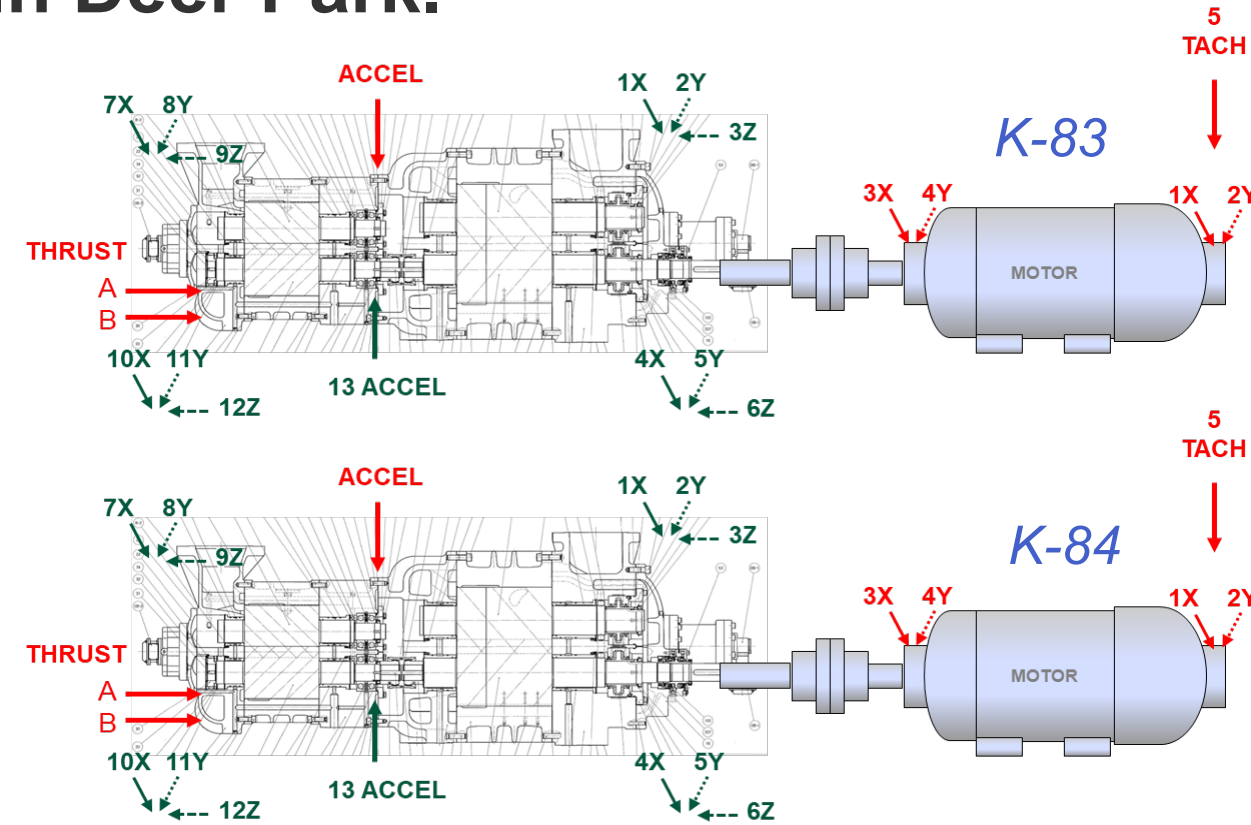

AMS Machine Works provides both familiar and tools for tracking and analyzing rotating machinery faults.

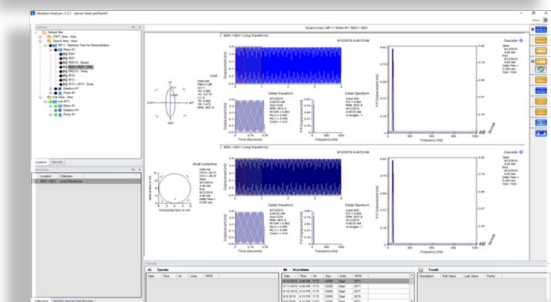

Motor driven Centrifuges with obsolete BN 3300 Mini Racks in Deer Park.

Customer Challenge

- Two motor driven centrifuges were on BN3300 obsolete machinery protection systems
- The cabinets were old and rusty, with electronics inside causing failures. Needed completely new air purged stainless steel cabinets with HMI's and state of the art monitoring system communicating to the DCS.

Solution

- Puffer did a machine walkdown, recommended the following:
 - Full turnkey project to replace these two machines with a brand-new upgraded cabinet installed with AMS 6500 ATGs connected to new Tri-axial IMI accelerometers, existing speed probes and temperature sensors -- RTDs

Result

- Total amount for the project: Two racks with cabinets new Tri-axial sensors and was **\$278,449** covering hardware, software commissioning services and new air purged cabinet.
- State-of-the art vibration monitoring system communicating to the DeltaV DCS and protecting the machines

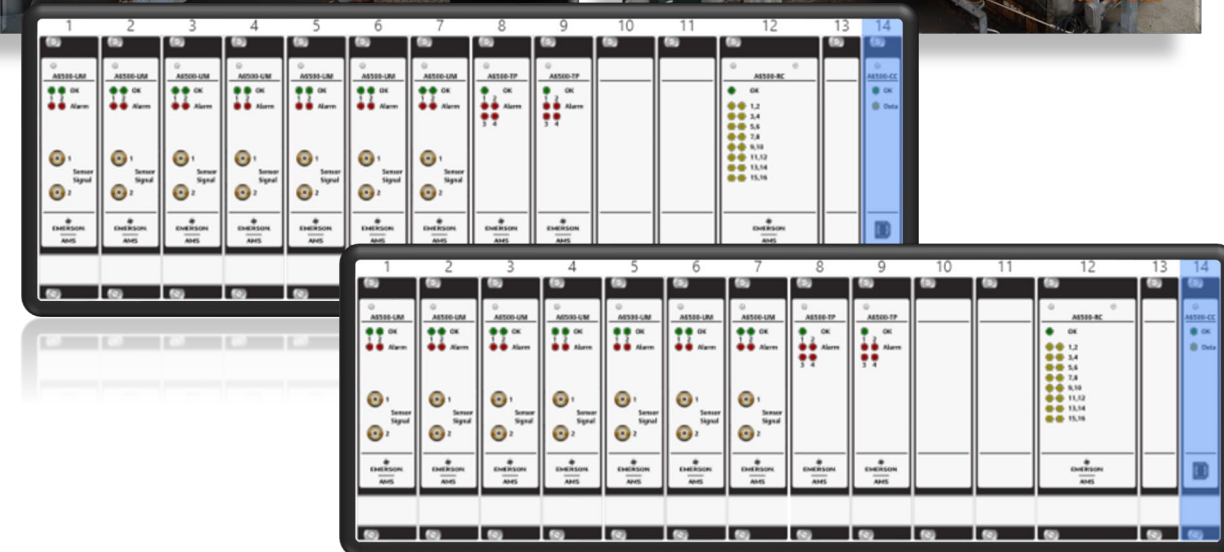
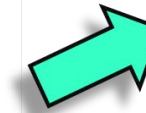

Two 2-Stage Motor driven Nitrogen Centrifugal Compressors with obsolete BN 3300 systems in Longview, TX ASU



Customer Challenge

- Before AMS 6500 ATG solution design, customer had obsolete BN 3300 old racks. .
- Customer had a failure in Asia which resulted in the loss of life, damaged property and goodwill of the company.

Solution

- Scope of project covered 1 X AMS 6500 ATG rack monitoring 2 X 2-Stage N2 Compressors with a full suite of EZ1000 Probe Driver Eddy Current transducers systems, Junction boxes, AMS Machine Works licenses and Cabinets with FAT, SAT and full commissioning Services.

Result

- We were able to combine 2 Compressors on one AMS 6500 ATG Rack saving them cost, services included re-using the existing cabinet, Full ATG rack with new sensors **\$77,941** connected to DeltaV DCS.
- Customer has standardized this solution fleetwide, it protects the compressors, capture vibration data and sends it to AI Models for analytics in PRISM at the enterprise monitoring center.

Pi Historian

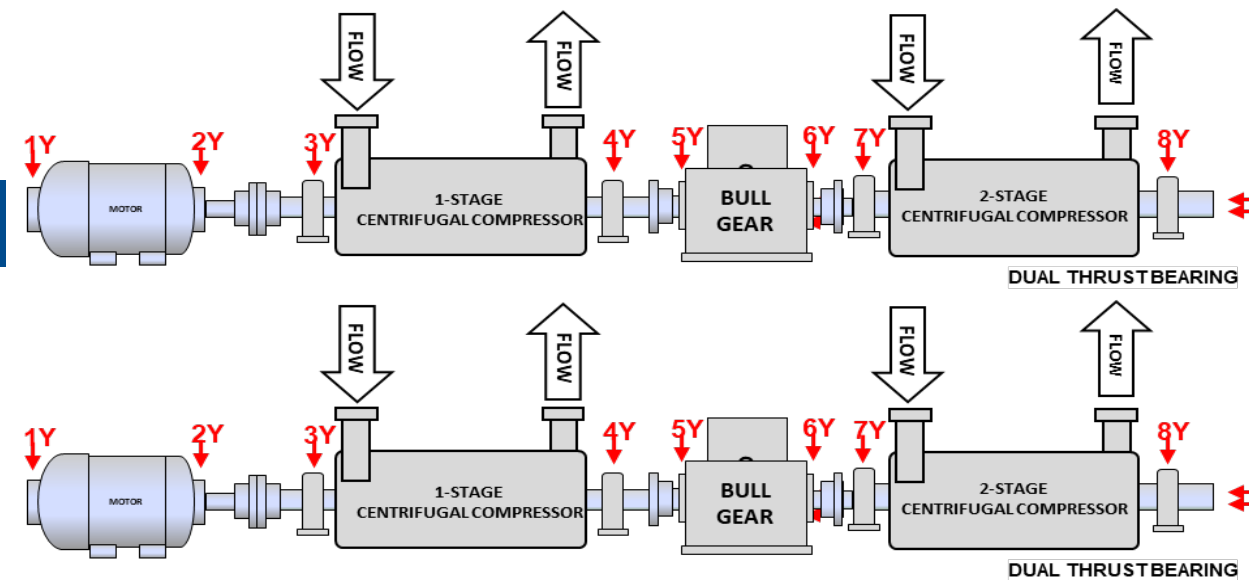
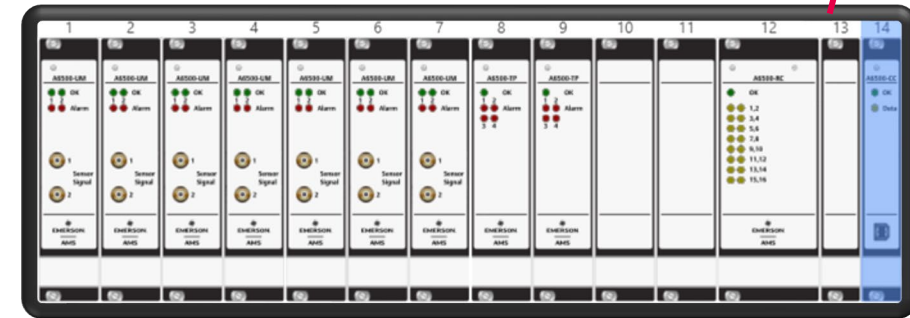

AMS EZ 1000 Eddy Current Sensor System



Supporting Collateral

Salim Jaffer

Protection System Modernization Flyer



AMS 6500 ATG allows users to confidently, cost-effectively introduce predictive intelligence while modernizing their existing protection system.

Emerson has delivered prediction technologies to customers since 1985. With more than 35 years of experience in the design and installation of protection systems, we boast a modern alternative to protecting your critical assets.

100+
Obsolete systems
replaced since
2012

3000+
Turbo machines
protected by
Emerson



AMS 6500 ATG allows users to confidently, cost-effectively introduce predictive intelligence while modernizing their existing protection system.

NO TIME TO SPARE?
We are currently stocked & ready to ship our systems to customers.



Emerson's AMS 6500 ATG

- API 670 compliant TSI protection system
- Embedded predictive diagnostics including PeakVue™ technology, order analysis, bend analysis and energy in bands
- Communicate and use with AMS Machine Works to harness Advanced Analysis Tools.
- Interface with other applications through OPC UA, Modbus TCP/IP, or Modbus RTU
- SNTP time synchronization
- 42-Month warranty
- Airborne contaminants resistance class G3 according to ISA-571.04

AMS 6500 ATG is a class-leading, field-proven solution to protection system modernization.

Plants looking for the advantages of a modern protection system are turning to Emerson's AMS 6500 ATG system - an API 670-compliant protection system with embedded prediction technology.

Emerson has delivered prediction technologies to customers since 1985. With more than 35 years of experience in the design and installation of protection systems, we boast a modern alternative to protecting your critical assets.

100+
Obsolete systems
replaced since
2012

3000+
Turbo machines
protected by
Emerson

AMS



Flexible & Cost-effective

Lower total cost of ownership with universal monitor and process cards featuring user-configurable inputs, allowing for I/O changes in the field and requiring fewer spare cards to accommodate a wide range of measurement types. The A6500-UM cards are designed to work with your existing sensors, eliminating installation labor cost associated with the upgrade.

Accessible & Integrable

Stay in touch with your asset's health from anywhere with the latest modern technology you use in daily life. The AMS 6500 ATG easily connects to existing DCS/PLC, Historian, or HMI systems via OPC UA and Modbus TCP and RTU. All information is available via mobile app.

Prediction

Know the health of the asset using the powerful embedded prediction capabilities included in all of Emerson's vibration analysis solutions, including PeakVuePlus technology for the earliest indication of failure.

Safe & Compliant

The AMS 6500 ATG is API 670 compliant and meets various safety certification required for use in hazardous environments: CSA Class 1 Div 2, IECEx Zone 2, ATEX, and DNV GL certifications.

Out-of-the-box Analysis Tools

Machine Studio Configuration Software and ATG View Mobile App



Machine Studio configuration software for AMS 6500 ATG is designed based on human-centered design to be intuitive and easy. Perform system configurations, define functionality for a UM module and develop trip logic. While connected, the user has access to the integrated prediction functionality, which is used to configure the ATG cards. Results of the prediction functionality are displayed in the configuration software.



The ATG View Mobile App delivers asset health information to the user anywhere on the plant network.



Complimentary Solution

AMS 6500 ATG with AMS Machine Works software



Emerson's AMS 6500 ATG communicates directly over Ethernet to AMS Machine Works to provide high resolution waveform and spectrum analysis and "transient" recordings of data, all available on demand, by alert or scheduled.

In addition to modernizing their protection system, this complimentary solutions allow users to unite condition monitoring data from other Emerson vibration hardware into one suite for analysis and machinery health.

Updated Protection System Migration Video

- Customer-facing protection system migration video
 - Use existing Cabinet
 - AMS 6500 ATG fits in existing footprint
 - Use existing sensors (or upgrade to AMS EZ1000)
 - Re-configure logic in AMS 6500 ATG
 - Enjoy benefits of modern AMS 6500 ATG protection system
- Available from Emerson [website](#)
- YouTube: <https://youtu.be/S-L5csi661c>



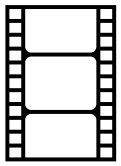

Protection System Modernization to the AMS 6500 ATG

Field-Proven Solution for Easy,
Affordable Upgrade from Legacy Systems



Easy Integration into Delta V

Björn Müller

DeltaV Integration – What, Why, How ??

Excel spread sheet with Modbus address or OPC UA Path

AMS 6500 ATG Application Memory

Emerson DeltaV DCS



i) Data Exchange

- Modbus TCP Interface
- OPC UA Interface

ii) User Interface

- Machine Train Graphics
- VMS/MMS Rack Diagnostics Graphics

Modbus Data Mapping

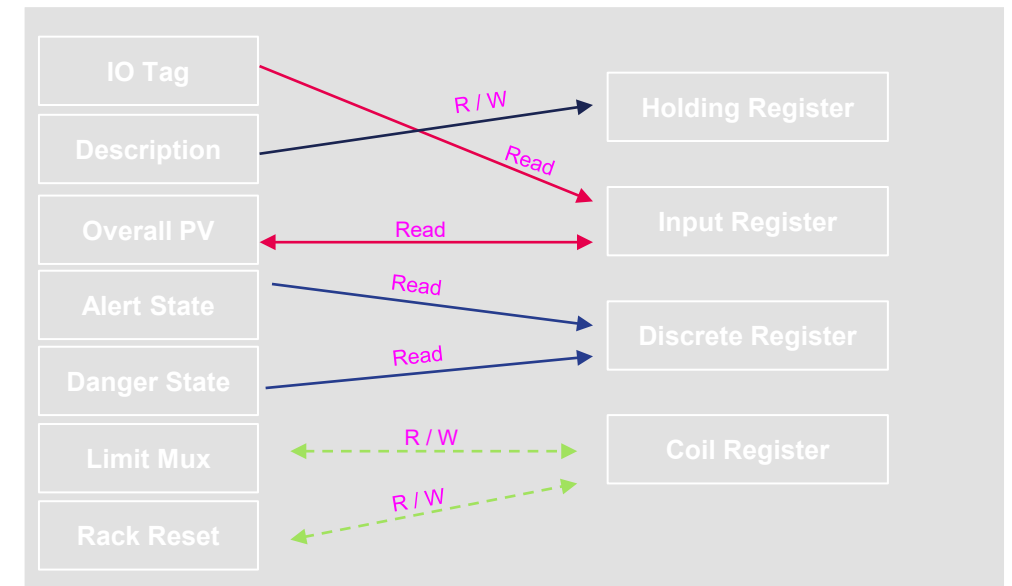

OPC UA

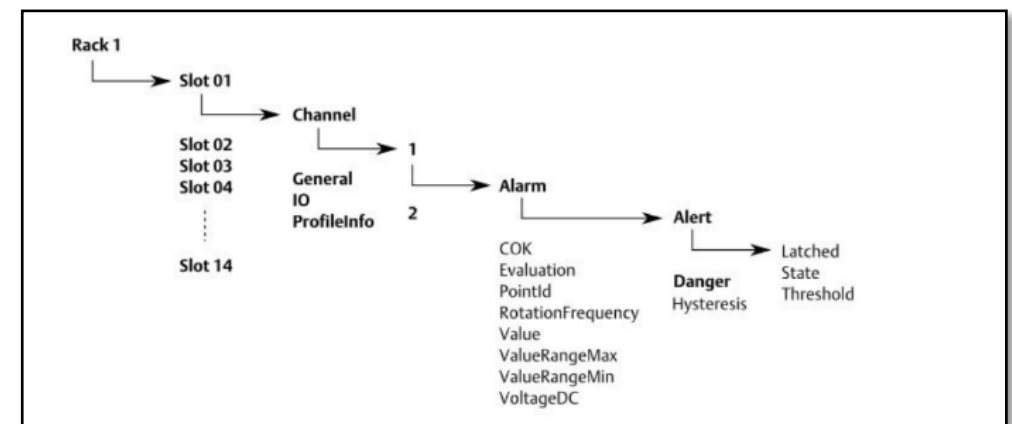

Simplified Network Architecture

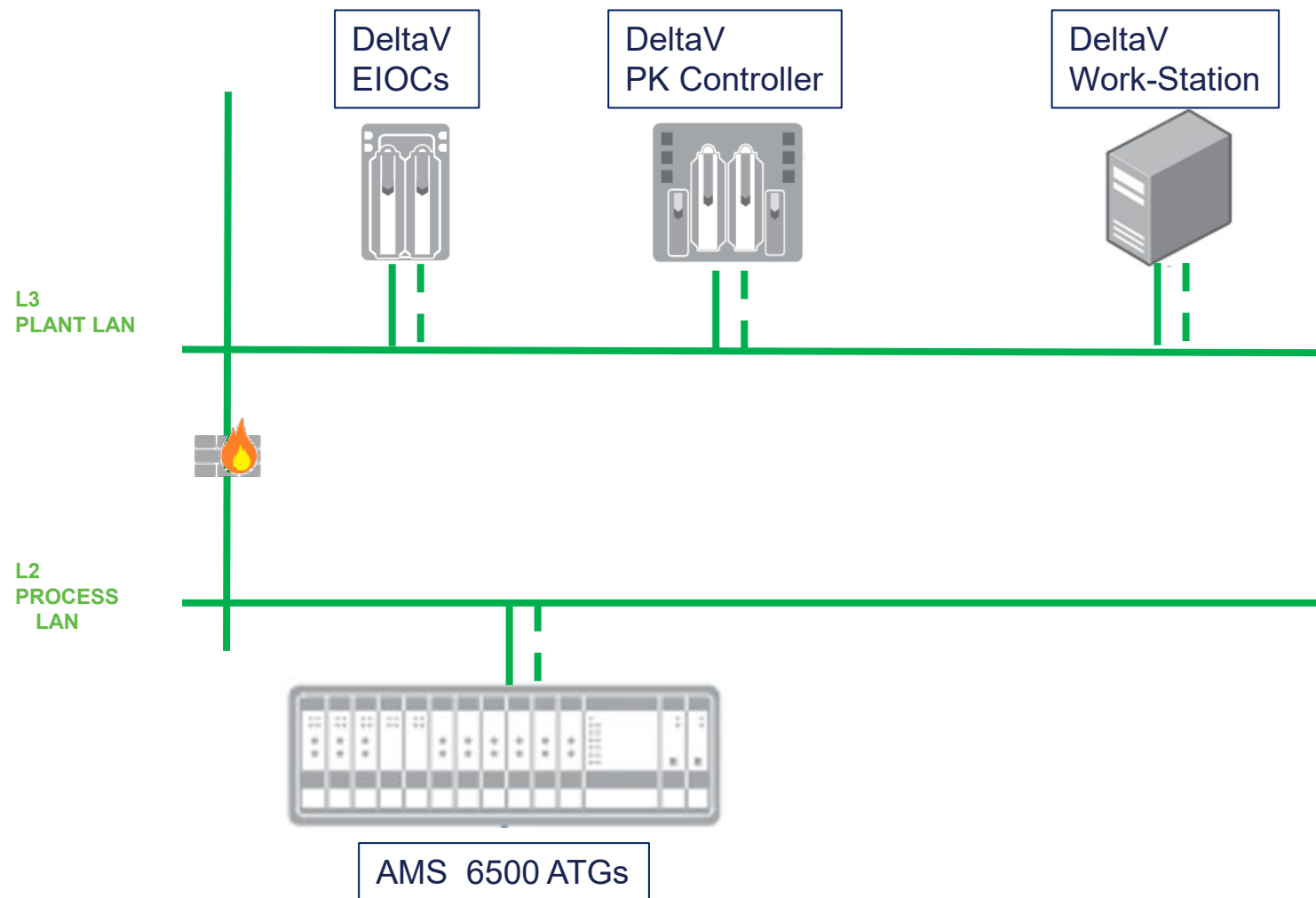

FLOW DIAGRAM

MODBUS / OPC-UA

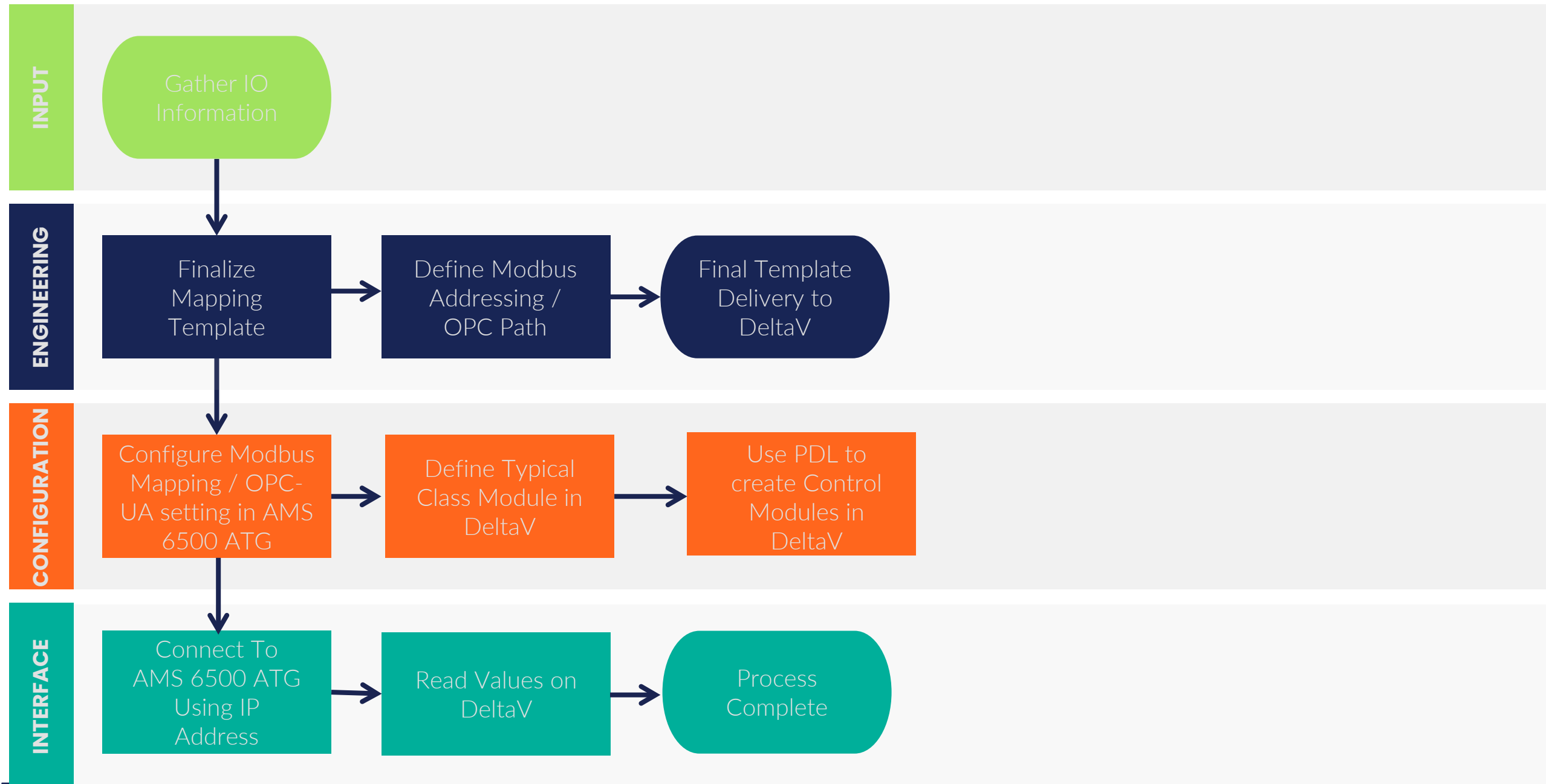

Integrated Machinery Protection System

Standardized →

Architecture

Integration

GUI

- DeltaV Ethernet IO card integrates easily via Modbus TCP or OPC UA
- Integrated scalar values, card and sensor status

- Standard database templates & PDL tool make integration faster and error free
- Create standardized asset strategies across your enterprise with ease

- Standard GUI elements like GEMs, Graphical templates, Status displays.
- Alerts integrated into standard operator alert monitors

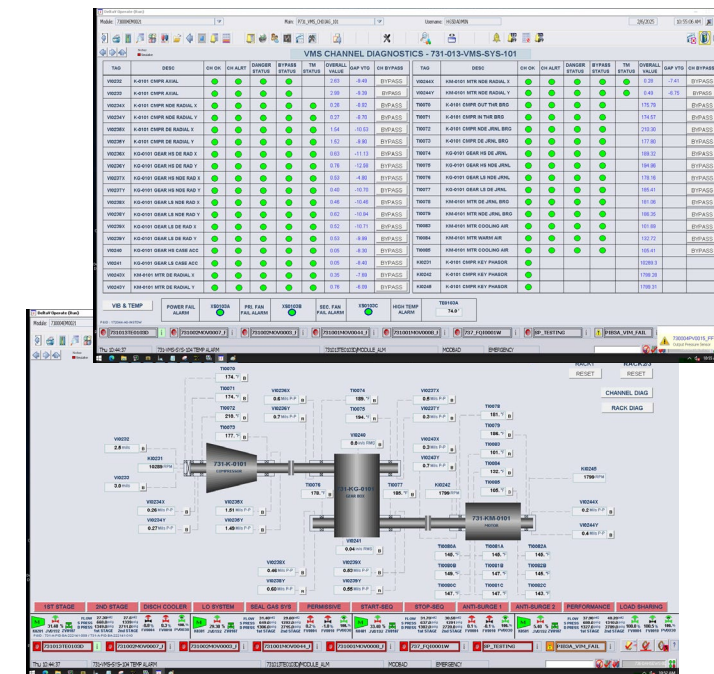
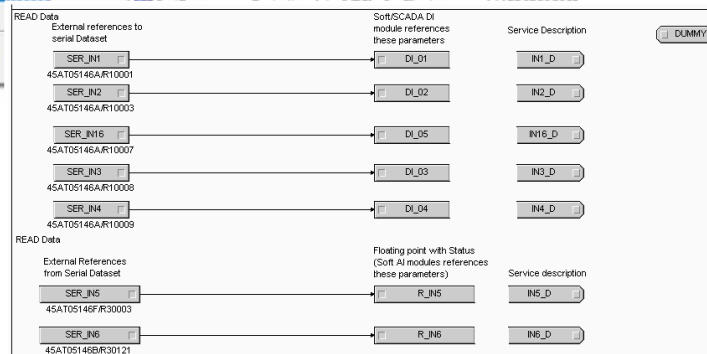
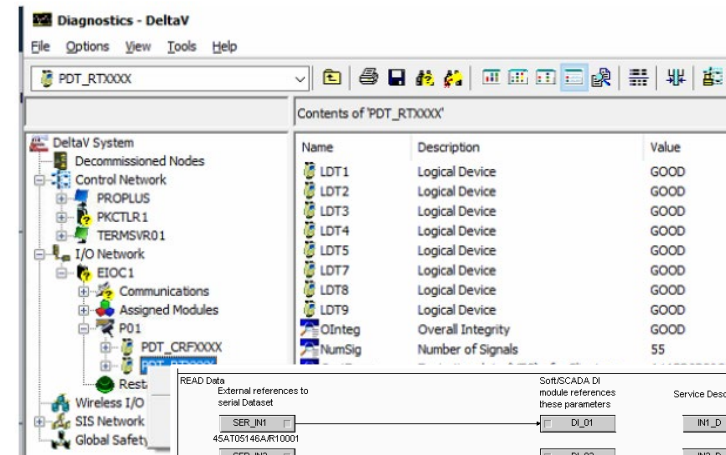

Exhibit # 39

Find More Information

www.emerson.com/ams

Contacts

Bjoern.Mueller@emerson.com

Salim.Jaffer@puffer.com



EMERSON EXCHANGE 2025

ACCELERATING
INNOVATION

Thank You